

TECHNICAL DATA SHEET

DELTA®-TERRAXX/PLUS

For Heavy Duty Vertical and Horizontal Drainage Applications.

MATERIAL

DELTA®-TERRAXX is a high performance, 3-dimensional drainage composite. It consists of a dimpled drainage core and a layer of high strength polypropylene (PP) geotextile. The thin 3-dimensional structure of the geotextile is engineered to reduce the risk of clogging. The geotextile is heat-bonded to dimples. Its high initial modulus prevents deformation under increasing load ensures that flow rates are not compromised. The drainage core is made from a special high-density polyethylene (HDPE) that provides high impact and tear-resistance and is unaffected by environmental stress-cracking. The non-clogging geotextile is fully bonded to the dimpled drainage core, which prevents it from being pushed into the flow channels thereby maintaining high flow rates.

PROPERTIES

DELTA®-TERRAXX provides a continuous path for water discharge and relieves hydrostatic pressure buildup. The non-woven gray geotextile allows water to pass freely into the drainage core. At the same time, it prevents the passage of soil particles to ensure that the drainage core doesn't get clogged. DELTA®-TERRAXX is the ideal solution for applications where high drainage capacity is required. Subsurface water can pass easily into the drainage core where gravity feeds it into the drainage system at the bottom of the foundation. The product is rot-proof.

Also available as DELTA®-TERRAXX PLUS, with an exclusive integrated self-adhesive flat tab for greater placement stability.

APPLICATION

It is suitable for applications in underground wall construction, caisson, pile and lagging wall drainage, retaining walls, bridge abutments, and as relief layer for hydrostatic pressure on any subsurface structure. It will also function as protection board in a waterproofing system.

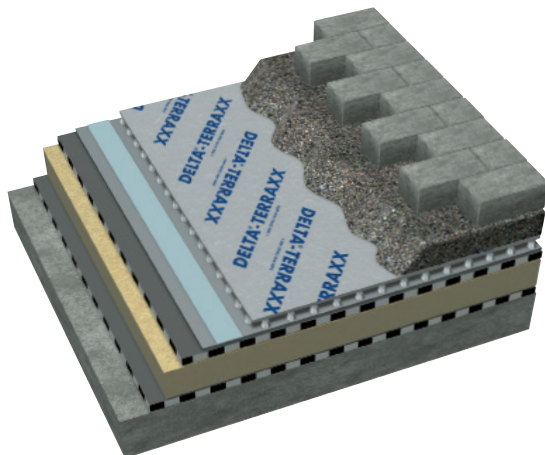

Technical Data

Product name	DELTA®-TERRAXX/PLUS	
Color	Silver	
Material	Drainage core:	
	high-density polyethylene (HDPE)	
	Geotextile: Polypropylene (gray)	
Dimple height	approx. 2/5" (9 mm)	ASTM D5199
Compressive strength	8,500 psf (406 kN/m ²)	ASTM D6364-06
Geotextile (gray) grab tensile strength	120 lbs (534 N)	ASTM D4632
Geotextile (gray) elongation	60%	ASTM D4632
Geotextile (gray) trapezoidal tear	35 lbs (156 N)	ASTM D4533
Geotextile (gray) puncture strength	25 lbs (110 N)	ASTM D4833
Geotextile (gray) apparent opening size (AOS)	50 sieve size (0.30 mm)	ASTM D4751-99
Geotextile (gray) water flow rate	95 gal/min/ft ² (3895 l/min/m ²)	ASTM D4491
Permittivity	0.8 sec ⁻¹	ASTM D4491
Geotextile (gray) weight (typical)	3.0 oz/yd ² (104 g/m ²)	ASTM D5261-92
Geocomposite water flow rate @ hydr. grad. 1.0	16.6 gal/min/ft (206 l/min/m)	ASTM D4716-99
Geocomposite water flow rate @ hydr. grad. 0.1	4.77 gal/min/ft (59 l/min/m)	ASTM D4716-99
Toxicity	non-toxic, non-polluting	
Roll size / weight	6'-7" x 41' (2 m x 12.5 m) 51 lbs (23 kg)	
Service life expectancy	> 25 years (at pH between 4 and 9 and temperature below 77°F / 25°C). Do not expose to UV light for more than 30 days.	

DELTA® products support sustainable and energy-efficient building practices, including efforts toward achieving LEED® certification (LEED® for New Construction & Major Renovations, LEED® for Core and Shell, LEED® for Existing Buildings and LEED® for Homes).

For technical support, call our technical support team at 1-888-4DELTA4 (1-888-433-5824) extension 326, or visit www.dorken.com.

PLEASE SEE [HTTPS://WWW.DORKEN.COM/EN/](https://www.dorken.com/en/) for the .DOCX VERSIONS OF THESE MASTER SPECS.

DÖRKEN SYSTEMS INC. GUIDE NOTE: This master specification section includes DÖRKEN SYSTEMS INC. GUIDE NOTES identified as “DÖRKEN SYSTEMS INC. GUIDE NOTE” for information purposes and to assist the specification writer in making appropriate decisions. The DÖRKEN SYSTEMS INC. GUIDE NOTE always immediately precedes the text to which it is referring. The section serves as a guideline only and should be edited with deletions and additions to meet specific project requirements.

DÖRKEN SYSTEMS INC. GUIDE NOTE: This specification section follows the recommendations of the Construction Specifications Canada, Manual of Practice including MasterFormat™, SectionFormat™, and PageFormat™. Optional text is indicated by square brackets [_____]; delete the optional text including the brackets in the final copy of the specification. Delete the DÖRKEN SYSTEMS INC. GUIDE NOTES in the final copy of the specification. Trade/brand names with appropriate product model numbers, styles and types are used in DÖRKEN SYSTEMS INC. GUIDE NOTES and in the specification text Article or Paragraph titled “Acceptable Material”.

DÖRKEN SYSTEMS INC. GUIDE NOTE: This specification Section is based upon the Dörken Systems Inc., DELTA®-TERRAXX/PLUS.

Part 1 General

1.1 SUMMARY OF WORK

- .1 This Section specifies geocomposite drainboard for [vertical foundation wall], [split slab], [plaza deck], [inverted roof] [planter drainage], [lagging wall] applications, and supporting accessories.

1.2 RELATED REQUIREMENTS

DÖRKEN SYSTEMS INC. GUIDE NOTE: Include in this Paragraph only those sections and documents that directly affect the work of this section. If a reader of this section could reasonably expect to find a product or component specified in this section, but it is actually specified elsewhere, then the related section number(s) should be listed in the Paragraph below. Do not include Division 00 Documents or Division 01 Sections since it is assumed that all technical sections are related to all project Division 00 Documents and Division 01 Sections to some degree. Refer to other documents with caution since referencing them may cause them to be considered a legal part of the Contract. Edit the following paragraphs to suit specific project conditions.

- .1 Section 07[__] [__] - [__ Waterproofing].
- .2 Section [_____].

1.3 ALTERNATIVES

- .1 Product Alternatives in accordance with Section [01 23 00 – Alternatives].

DÖRKEN SYSTEMS INC. GUIDE NOTE: In the following Article, include only those reference standards which appear in the finished version of the project specification.

1.4 REFERENCE STANDARDS

- .1 ASTM International (ASTM).
 - .1 ASTM D4491 - [1999a(2009)], Standard Test Methods for Water Permeability of Geotextiles by Permittivity.
 - .2 ASTM D4533 - [2011], Standard Test Method for Trapezoid Tearing Strength of Geotextiles.
 - .3 ASTM D4632 - [2008], Standard Test Method for Grab Breaking Load and Elongation of Geotextiles.
 - .4 ASTM D4716 - [2008], Standard Test Method for Determining the (In-plane) Flow Rate per Unit Width and Hydraulic Transmissivity of a Geosynthetic Using a Constant Head.
 - .5 ASTM D4751 - [2004], Standard Test Method for Determining Apparent Opening Size of a Geotextile.

- .6 ASTM D4833 - [2007], Standard Test Method for Index Puncture Resistance of Geomembranes and Related Products.
- .7 ASTM D5261 - [2010], Standard Test Method for Measuring Mass per Unit Area of Geotextiles.
- .8 ASTM D6364-06, Standard Test Method for Determining Short-Term Compression Behavior of Geosynthetics.
- .2 Canada Green Building Council (CaGBC).
 - .1 LEED Canada-NC Version 4 Building Design and Construction (BD+C), LEED (Leadership in Energy and Environmental Design): Green Building Rating System Reference Package For New Construction and Major Renovations.

1.5 ADMINISTRATIVE REQUIREMENTS

- .1 Co-ordination: Co-ordinate work of this Section with work of adjacent trades for proper time and sequence to avoid construction delays.
- .2 Pre-installation Meeting: Convene pre-installation meeting after Award of Contract and one week prior to commencing work of this Section to verify project requirements, substrate conditions and co-ordination with other building sub-trades, and to review manufacturer's written installation instructions.
 - .1 Comply with Section [01 31 19 - Project Meetings] and co-ordinate with other similar pre-installation meetings.
 - .2 Notify attendees 2 weeks prior to meeting and ensure meeting attendees include as minimum:
 - .1 Consultant;
 - .2 Geocomposite drainboard installer;
 - .3 Waterproofing installer;
 - .4 Manufacturer's Technical Representatives.
 - .3 Ensure meeting agenda includes review of methods and procedures related to geocomposite drainboard installation including co-ordination with related and adjacent work.
 - .4 Record meeting proceedings including corrective measures and other actions required to ensure successful completion of work and distribute to each attendee within 1 week of meeting.

[DÖRKEN SYSTEMS INC. GUIDE NOTE: Delete the section below for proprietary based product specifications.](#)

1.6 PERFORMANCE REQUIREMENTS

- .1 Select and install geocomposite drainboard and accessory materials by same manufacturer to drain moisture under hydrostatic pressure away from [vertical foundation walls], [split slabs], [plaza decks], [inverted roofs] [planter drainage], [lagging wall] applications with a geotextile water flow rate of 3895 l/min/m² (595 gal/min/ft²) as measured in accordance with ASTM D4491 and a geocomposite water flow rate @ hydraulic gradient of 1.0: 206 l/min/m (16.6 gal/min/ft) with ASTM D4716.

[DÖRKEN SYSTEMS INC. GUIDE NOTE: Article below includes submittal of relevant data to be furnished by Contractor.](#)

1.7 ACTION AND INFORMATIONAL SUBMITTALS

- .1 Provide submittals in accordance with Contract Conditions and Section [01 33 00 - Submittal Procedures].
- .2 Product Data: Submit product data including manufacturer's literature for geocomposite drainboard materials and accessories, indicating compliance with specified requirements and material characteristics.
 - .1 Submit list on geocomposite drainboard manufacturer's letterhead of materials and accessories to be incorporated into Work.
 - .2 Submit Product Data Sheets in accordance with Section [01 33 00 – Submittal Procedures].
 - .3 Include product names, types and series numbers.

- .4 Include substrate preparation instructions, installation methods, storage and handling requirements.
- .5 Include contact information for manufacturer and their representative for the Project.
- .3 Submit drawings stamped and signed by professional engineer registered or licensed in [Province] [Territory], Canada.
 - .1 Submit drawings of special conditions [and] [_____].
- .4 Samples:
 - .1 Submit [quantity] [100 x 100] mm minimum sample of the geocomposite drainboard.
 - .2 Submit [300] mm long minimum sample of each type of tape.
 - .3 Submit each type of fastener.
- .5 Quality Assurance Submittals: submit following in accordance with Section [01 45 00 - Quality Control].
 - .1 Existing Substrate Condition: report deviations, as described in PART 3 -EXAMINATION in writing to Consultant.
 - .2 Certificates: submit certificates signed by manufacturer certifying that materials comply with specified performance characteristics and physical properties.
 - .3 Manufacturer's Instructions: submit manufacturer's installation instructions and special handling criteria, installation sequence, cleaning procedures and [_____].
- .6 Field Reports: Submit manufacturer's field reports within 3 days of each manufacturer representative's site visit and inspection.
- .7 Sustainable Design (LEED).
 - .1 LEED Submittals: In accordance with Section [01 35 21 – LEED Requirements].
- .8 Installer Qualifications:
 - .1 Submit letter verifying installer's experience with work similar to work of this Section.
- .9 Closeout Submittals
 - .1 Operation and Maintenance Data: Supply maintenance data for geocomposite drainboard materials for incorporation into manual specified in Section [01 78 00 - Closeout Submittals].

[DÖRKEN SYSTEMS INC. GUIDE NOTE: If LEED is not a part of the project delete the following Paragraph in its entirety as well as the reference standards in 1.03.6.](#)

- .2 Sustainable Design Closeout Documentation (LEED).
 - .1 Provide calculations on end-of-project recycling rates, salvage rates, and landfill rates for work of this Section demonstrating percentage of construction wastes which were recycled.
 - .2 Submit verification from recycling facility showing receipt of materials.
 - .3 Record Documentation: In accordance with Section [01 78 00 - Closeout Submittals].
 - .1 List materials used in geocomposite drainboard work.
 - .2 Warranty: Submit warranty documents specified.

1.8 QUALITY ASSURANCE

- .1 Installer Quality Assurance: Work experience from [5] projects minimum with work similar to work of this Section.
- .2 Sustainability Standards Certification (LEED).
 - .1 LEED submittals: In accordance with Section [01 35 21 - LEED Requirements].

[DÖRKEN SYSTEMS INC. GUIDE NOTE: Use the following paragraph only if geocomposite drainboard extends more than 3,000 square](#)

[metres, and is of a repetitive or critical nature.](#)

- .3 Mock-Up:
 - .1 Construct mock-up in accordance with Section [01 45 00 - Quality Control].
 - .2 Construct typical [exterior foundation] [flat surface area] panel, [_____] m long by [_____] m wide, incorporating [shingled install of waterproofing and geocomposite drainboard] [and] [lapping adhesion].
 - .3 Locate [where directed].
 - .4 Mock-up may [not] [_____] remain as part of finished work.
 - .5 Allow [24] hours for inspection of mock-up by Consultant before proceeding with air/vapour barrier Work.
- .4 Site Meetings: as part of Manufacturer's Services described in PART 3 - FIELD QUALITY CONTROL, schedule site visits, to review Work, at stages listed.
 - .1 After delivery and storage of products, and when preparatory Work is complete, but before installation begins.
 - .2 [Twice] during progress of Work at [25%] and [60%] complete.
 - .3 Upon completion of Work, after cleaning is carried out.

[DÖRKEN SYSTEMS INC. GUIDE NOTE: The following Article although not part of Quality Assurance, can be used to enhance the quality of materials by ensuring that they are delivered and handled properly at the work site.](#)

1.9 DELIVERY STORAGE AND HANDLING

- .1 Delivery and Acceptance Requirements:
 - .1 Deliver material in accordance with Section [01 61 00 - Common Product Requirements].
 - .2 Deliver materials and accessories in manufacturer's original packaging with identification labels intact and in sizes to suit project.
- .2 Storage and Handling Requirements: Store materials off ground and protected from exposure to harmful weather conditions and at temperature conditions recommended by manufacturer.
 - .1 Ensure materials are protected from sunlight and UV radiation.
 - .2 Store and dispose of solvent-based materials, and materials used with solvent-based materials, in accordance with requirements of local authorities having jurisdiction.
- .3 Packaging Waste Management:

[DÖRKEN SYSTEMS INC. GUIDE NOTE: For smaller projects that do not have a separate Section for waste management and disposal, delete the following paragraph.](#)

- .1 Separate and recycle waste packaging materials in accordance with Section [01 74 19 - Construction Waste Management and Disposal].
- .2 Remove waste packaging materials from site and dispose of packaging materials at appropriate recycling facilities.

[DÖRKEN SYSTEMS INC. GUIDE NOTE: For smaller projects that do not have a Waste Management Plan, delete the option referring to a Waste Management Plan.](#)

- .3 Collect and separate for disposal paper and plastic material in appropriate on-site storage containers for recycling [in accordance with Waste Management Plan].

1.10 WARRANTY

- .1 Project Warranty: Refer to Contract Conditions for project warranty provisions.

- .2 Manufacturer's warranty: Submit, for Owner's acceptance, manufacturer's standard warranty document executed by authorized company official. Manufacturer's warranty is in addition to and not intended to limit other rights Owner may have under Contract Conditions.

DÖRKEN SYSTEMS INC. GUIDE NOTE: Coordinate article below with manufacturer's warranty requirements.

- .3 Warranty period: [10] years commencing on Date of Substantial Performance of Work.

Part 2 Products

2.1 MANUFACTURER – PROPRIETARY BASED

- .1 Manufacturer: Dörken Systems Inc., 4655 Delta Way, Beamsville, Ontario, L3J 0T6, Canada, Phone: 1-905-563-3255, Toll Free: 1-888-4DELTA4 (1-888-433-5824), e-mail: info@dorken.com , URL: <http://www.dorken.com>.

DÖRKEN SYSTEMS INC. GUIDE NOTE: Delete the section below for performance-based product specifications or delete the appropriate section based on project requirements.

2.2 MATERIALS – PERFORMANCE BASED

- .1 Two-layer geocomposite drainboard with dimpled non-clogging high density polypropylene (HDPE) drainage core and heat-bonded polypropylene geotextile for vertical applications.
- .2 Two-layer geocomposite drainboard with dimpled non-clogging high density polypropylene (HDPE) drainage core and heat-bonded polypropylene geotextile with factory-applied adhesive overlap edge for horizontal applications.
- .3 Two-layer geocomposite drainboard with dimpled non-clogging high density polypropylene (HDPE) drainage core and heat-bonded polypropylene geotextile for blindside applications.

DÖRKEN SYSTEMS INC. GUIDE NOTE: Delete the section below for performance-based product specifications or delete the appropriate section based on project requirements.

2.3 MATERIALS – PROPRIETARY BASED

- .1 Two-layer geocomposite drainboard with dimpled non-clogging high density polypropylene (HDPE) drainage core and heat-bonded polypropylene geotextile for vertical applications.
 - .1 Acceptable Material: DELTA®-TERRAXX.
- .2 Two-layer geocomposite drainboard with dimpled non-clogging high density polypropylene (HDPE) drainage core and heat-bonded polypropylene geotextile with factory-applied adhesive overlap edge for horizontal applications.
 - .1 Acceptable Material: DELTA®-TERRAXX PLUS.
- .3 Two-layer geocomposite drainboard with dimpled non-clogging high density polypropylene (HDPE) drainage core and heat-bonded polypropylene geotextile for blindside applications.
 - .1 Acceptable Material: DELTA®-TERRAXX.

DÖRKEN SYSTEMS INC. GUIDE NOTE: Delete the section below for proprietary-based product specifications.

2.4 PERFORMANCE CRITERIA

- .1 Dimpled Sheet Compressive Strength: 406 kN/m² (8,500 psf) to ASTM D6364.
- .2 Geotextile grab tensile strength: 534 N (120 lbs) to ASTM D4632.
- .3 Geotextile elongation: 60% to ASTM D4632.

- .4 Geotextile trapezoidal tear: 156 N (35 lbs) to ASTM D453.
- .5 Geotextile puncture strength: 110 N (25 lbs) to ASTM D4833.
- .6 Geotextile apparent opening size (AOS): 0.30 mm (50 sieve size) to ASTM D4751-99.
- .7 Geotextile water flow rate: 3895 l/min/m² (595 gal/min/ft²) to ASTM D449.
- .8 Permittivity: 0.8 sec-1 to ASTM D449.
- .9 Geotextile weight (typical): 104 g/m² (3.0 oz/yd²) to ASTM D5261.
- .10 Geocomposite water flow rate @ hydr. grad. 1.0: 206 l/min/m (16.6 gal/min/ft) to ASTM D4716.
- .11 Geocomposite water flow rate @ hydr. grad. 0.1: 59 l/min/m (4.77 gal/min/ft) to ASTM D4716.
- .12 Toxicity: Non-polluting and non-toxic.

[DÖRKEN SYSTEMS INC. GUIDE NOTE: Delete the section below for performance-based product specifications.](#)

2.5 ACCESSORIES – PROPRIETARY BASED

- .1 Multi-Stud Fasteners:
 - .1 Acceptable Material: DELTA®-FAST'ner.
- .2 Termination Strip:
 - .1 Acceptable Material: DELTA®-MOLDSTRIP or DELTA®-FLASH
- .3 Acrylic Adhesive Tape:
 - .1 Acceptable Material: DELTA®-MULTI BAND.
- .4 Flashings and Edge Strip: Black recycled moulded polyethylene flashing.
 - .1 Acceptable material: Dörken Systems Inc., DELTA®-MOLDSTRIP or DELTA®-FLASH.

[DÖRKEN SYSTEMS INC. GUIDE NOTE: Delete the section below for proprietary-based product specifications.](#)

2.6 ACCESSORIES – PERFORMANCE-BASED

- .1 Corrosion-resistant concrete nails (([]"Ø), []" embedment minimum)) with washer, termination strip, acrylic adhesive tape, edge strip and flashings as per geocomposite drainboard manufacturers written installation instructions.

2.7 PRODUCT SUBSTITUTIONS

- .1 Substitutions: [In accordance with Section 01 23 13 - Product Substitution Procedures] [No substitutions permitted].

Part 3 Execution

3.1 EXAMINATION

- .1 Verification of Conditions: Verify that conditions of substrate previously installed under other Sections or Contracts are acceptable in accordance with the methods required by the manufacturer for geocomposite drainboard.
 - .1 Visually inspect substrate in presence of Consultant and Contractor.
 - .2 Inform Consultant of unacceptable conditions immediately upon discovery.
 - .3 Proceed with installation only after unacceptable conditions have been remedied and after receipt of written approval to proceed from Consultant.

[DÖRKEN SYSTEMS INC. GUIDE NOTE: Delete the line below for vertical applications of geocomposite drainboard.](#)

- .4 Proceed with installation only when no standing water is present.

3.2 PREPARATION

- .1 Clean surfaces "broom clean" prior to installation.
- .2 Prepare surfaces using the methods required by the manufacturer for achieving the best result for the substrate under the project conditions.
 1. Remove projections larger than [6] mm that can pierce the board; remove sharp edges.
 2. In concrete and masonry, patch cracks and holes to ensure suitable substrate in accordance with geocomposite drainboard manufacturer's written recommendations.
 3. Ensure there are no voids in lagging wider than 50mm (2").
- .3 Mark installation locations on walls before starting installation.

3.3 APPLICATION

- .1 Compliance: comply with manufacturer's written installation instructions or specifications, including product technical bulletins, handling, storage and installation instructions, and datasheets.
- .2 Vertical Foundation Wall Applications: Install geocomposite drainboard with flat side against wall over [waterproofing] [dampproofing] from bottom of wall to grade level, and in locations indicated.
- .3 Split Slab Applications: Install horizontal application geocomposite drainboard between mud slab and finish slab with flat side against waterproofing and fabric side up.
- .4 Inverted Roof Applications: Install horizontal application geocomposite drainboard with flat side against deck over waterproofing membrane.
- .5 Planter Applications: Install geocomposite drainboard with flat side against planter wall inside planters, over waterproofing.
- .6 Lagging Wall Applications: Install geocomposite drainboard with flat side against wall and fabric against lagging wall on entire surface of walls prior to installation of foundation wall.
- .7 Plaza Decks: Install horizontal application geocomposite drainboard with flat side against deck over waterproofing membrane.

3.4 INSTALLATION – FOUNDATION WALL (POSITIVE SIDE)

[DÖRKEN SYSTEMS INC. GUIDE NOTE: Refer to the geocomposite drainboard manufacturer's current installation guide for detailed information regarding specific details. Install geocomposite drainboard in accordance with manufacturer's written instructions.](#)

[DÖRKEN SYSTEMS INC. GUIDE NOTE: Edit the following Article to ensure that only applications included in the project are specified.](#)

- .1 Install only when the ambient temperature is above minus 30 °C (minus 22 °F).
- .2 Install geocomposite drainboard with flat side against wall, geotextile facing the soil, and over waterproofing. Align and abut panels.
- .3 Vertical drainboard installation orientation:
 - .1 Begin installation starting at the final grade level down to the footing, and in other locations as indicated in the construction drawings.
 - .2 Position the first row of [multi-stud fasteners] [corrosion resistant nails] 200 mm (8") below the top of the geocomposite drainboard. Continue to fasten the geocomposite drainboard [multi-stud fasteners] [corrosion resistant nails] with corrosion resistant nails in a "W" pattern 305 mm (12") o/c. Distance between rows should be 100 mm to 150 mm (4" to 6"). Ensure anchors are a maximum of 75 mm (3") from the corner of a cast-in-place concrete foundation wall.

- .3 Overlap the end laps of the geocomposite drainboard by 150 mm (6") in a downward shingle fashion. Do not interlock the dimples.
- 4 Horizontal drainboard installation orientation:
 - .1 When the panels are installed horizontally, start at lowest point and work to top, running it the length of the sheets, and draping over the top of the footing.
 - .2 If the membrane is being installed horizontally, at end laps, strip back the geotextile of the adjoining layer. Cut back the core of the geocomposite drainboard by 100 mm (4"). Butt to the adjacent layer, overlapping the geotextile only. Do not interlock the dimples. Fasten in place with [multi-stud fasteners] [corrosion resistant nails] at 200 mm (8") o/c along the overlap.
 - .3 At side laps with the self-adhering flat tab, place the subsequent course on the flat tab of the previous course with the dimples butted together. Remove the release liner from the adhesive strip and press the sheets together, ensuring intimate contact between the drainboard and the adhesive strip. Overlap the excess fabric onto the adjoining sheet to keep out soil particulate.
- .5 Ensure anchors are a maximum of 75 mm (3") from the corner of a cast-in-place concrete foundation wall.
- .6 Install sheets without gaps, wrinkles, creases, or tears.
- .7 Fold the fabric over the top edge and fasten 200 mm (8") on center or use Flashings and Edge Strip to terminate the top edge at the final grade.

3.5 INSTALLATION – PODIUM DECK AND ROOFS (FLAT SURFACES)

[DÖRKEN SYSTEMS INC. GUIDE NOTE: Edit the following Article to ensure that only applications included in the project are specified.](#)

- .1 Install only when the ambient temperature is above minus 30 °C (minus 22 °F).
- .2 Roll out membrane onto waterproofed substrate with geotextile facing upward towards the overburden (cup side down, fabric side up). Align and abut layers.
- .3 At end laps, strip back the geotextile of the adjoining layer. Cut back the core of the geocomposite drainboard by 100 mm (4"). Butt to the adjacent layer, overlapping the geotextile only. Do not interlock the dimples.
- .4 At the side laps with the self-adhering flat tab, place the subsequent course on the flat tab of the previous course with the dimples butted together. Remove the release liner from the adhesive strip and press the sheets together, ensuring intimate contact between the drainboard and the adhesive strip. Overlap the excess fabric onto the adjoining sheet to keep out soil particulate.
- .5 Install sheets without gaps, wrinkles, creases, or tears.
- .6 On low-slope split slab installations, install with filter fabric side up; overlap upper drainage geotextile over lower drainage geotextile in shingle fashion.
 - .1 Anchor geocomposite drainboard sufficiently to prevent movement prior to and during installation of cover.
- .7 On plaza decks, ensure pavers are not installed directly on the geocomposite drainboard.
 - .1 Install fine gravel buffer layer between geocomposite drainboard and pavers.

[DÖRKEN SYSTEMS INC. GUIDE NOTE: Ensure product specified is capable of supporting dynamic and static loads for intended use.](#)

- .2 Ensure gravel buffer layer is sized to thickness to accommodate intended service loads.
- .3 Install with geotextile side up with butt joints.

[DÖRKEN SYSTEMS INC. GUIDE NOTE: Use the following paragraph if concrete is to be poured over the geocomposite drainboard.](#)

- .8 Tape joints with Acrylic Adhesive Tape as required to prevent ingress of concrete.
- .9 At inside and outside corners, install sheet as close to substrate as possible without breaking.

- .10 At bottom of walls, extend single sheet from wall to drainage pipe, if any.

3.6 INSTALLATION – BLIND SIDE APPLICATION (NEGATIVE SIDE)

[DÖRKEN SYSTEMS INC. GUIDE NOTE: Edit the following Article to ensure that only applications included in the project are specified.](#)

- .1 Install only when the ambient temperature is above minus 30 °C (minus 22 °F).
- .2 On lagging, pile, or earth forms, and other “blind” wall construction, install geocomposite drainboard with geotextile in contact with soil retention system. Align and abut layers.
- .3 At vertical joints, butt and tape geocomposite drainboard.
- .4 At horizontal joints fasten lower geocomposite drainboard along top edge.
 - .1 Overlap upper drainage geotextile over lower drainage geotextile in shingle fashion.
 - .2 Fasten through both geocomposite drainboard at lower edge of upper sheet.
- .5 Seal butt joints without the flat tab and adhesive strip on core side of geocomposite drainboard continuously with 100 mm (4”) acrylic adhesive tape.
- .6 At joints with the flat tab and adhesive strip, butt edges, place the subsequent course on the flat tab of the previous course with the dimples butted together. Remove the release liner from the adhesive strip and press the sheets together, ensuring intimate contact between the two drainboards.
- .7 Overlap the geotextile in a shingle fashion to prevent soil particulates from entering the air gap, potentially clogging the drainage core.
- .8 Joints with the self-adhering flat tab do not require additional tape.
- .9 Corrosion resistant nail length will vary depending upon the surface to which the prefabricated drain is being attached. Nails should have flat heads, and washers or wood strapping may be used to prevent the nail head from being driven through the geocomposite drainboard.
- .10 Fold the fabric over the top edge and fasten 200 mm (8”) on center.
- .11 At end laps, cut back the core of the geocomposite drainboard by 100 mm (4”). Fold the remaining geotextile in a manner designed to keep soil particulate from entering the air gap. Fasten in place 200 mm (8”) o/c.

3.7 FIELD QUALITY CONTROL

- .1 Field Inspection: Coordinate field inspection in accordance with Section [01 45 00 - Quality Control].

[DÖRKEN SYSTEMS INC. GUIDE NOTE: Specify requirements if manufacturers are to provide field quality control with onsite personnel for instruction or supervision of product installation, application, erection or construction. Manufacturer field reports are included under PART I, Action and Informational Submittals.](#)

- .2 Manufacturer’s Services:

[DÖRKEN SYSTEMS INC. GUIDE NOTE: Use the following Paragraphs only when manufacture’s field services are provided and are required to verify the quality of the installed components. Establish the number and duration of periodic site visits required by manufacturer and specify below. Consult manufacturer for services required. Delete if field services are not required.](#)

- .1 Coordinate manufacturer’s services with Section [01 45 00 - Quality Control].
 - .1 Have manufacturer review work involved in handling, installation, protection, and cleaning of geocomposite drainboard and accessories, and submit written reports in acceptable format to verify compliance of Work with Contract conditions.
 - .2 Completed installation must be approved by the material manufacturer.
- .2 Manufacturer’s Field Services: Provide manufacturer’s field services consisting of product use recommendations and periodic site visits for product installation review in accordance with manufacturer’s instructions.

- .1 Report any inconsistencies from manufacturer's recommendations immediately to Consultant.
- .3 Schedule site visits to review work at stages as required.

3.8 CLEANING

[DÖRKEN SYSTEMS INC. GUIDE NOTE: For smaller projects that do not have a separate Division 01 Section for cleaning, delete the reference to Section 01 74 00 – Cleaning in the following two Paragraphs.](#)

- .1 Progress Cleaning: Perform cleanup as work progresses with Section [01 74 00 - Cleaning and Waste Management].
 - .1 Leave work area clean at end of each day.
- .2 Final Cleaning: Upon completion, remove surplus materials, rubbish, tools, and equipment with Section [01 74 00 – Cleaning and Waste Management].
- .3 Waste Management:
 - .1 Co-ordinate recycling of waste materials with Section [01 74 19 - Construction Waste Management and Disposal].
 - .2 Collect recyclable waste and dispose of or recycle field generated construction waste created during construction or final cleaning related to work of this Section.
 - .3 Remove recycling containers and bins from site and dispose of materials at appropriate facility.

3.9 PROTECTION

- .1 Do not leave installed geocomposite drainboard exposed to UV light for longer than 30 days after installation.
- .2 Protect installed products and accessories from damage during construction
- .3 Prior to backfilling, inspect geocomposite drainboard for tears and other damage and repair.
- .4 Ensure backfilling does not damage geocomposite drainboard.
 - .1 Backfill and compact in lifts.
 - .2 Replace geocomposite drainboard damaged during backfilling.
- .5 Repair damage to adjacent materials caused by geocomposite drainboard installation.

END OF SECTION

DELTA®-TERRAXX

Structural and Hydraulic Loads Analysis

Under Soil and Overburden Structural Loads and Rainwater and Ground Water Hydraulic Loads



MORRISON HERSHFIELD

MH was requested by Dörken Systems to review the suitability of DELTA®-TERRAXX as a drainboard in several common waterproofing applications. The review included analysis of Structural Loads due to overburden, traffic, and lateral soil pressures. The review also included analysis of hydraulic loads due to rainwater and ground water flows. The waterproofing applications reviewed include:

- Foundation Wall Waterproofing – Positive Side
- Foundation Wall Waterproofing – Blindside
- Inverted Roof Assembly – Occupied Roof Terrace
- Green Roof Assembly – Unoccupied Extensive System
- Podium Deck Waterproofing – Landscaped Areas (Intensive Green Roof is similar)
- Podium Deck Waterproofing – Traffic Areas

DELTA®-TERRAXX is a high performance drainage composite consisting of dimpled drainage core and polypropylene geotextile. DELTA®-TERRAXX has the following characteristics:

- Compressive strength of 8,969 psf (**429 kPa**)¹
- Hydraulic flow capacity in the machine direction
 - Hydraulic flow capacity under 1.0m head of water (i.e. vertical orientation) of **3.44 LPS / m width²**
 - Hydraulic flow capacity under 0.1 m head of water (i.e. horizontal orientation) of **0.986 LPS / m width³**
- Hydraulic flow capacity in cross-machine direction
 - Hydraulic flow capacity under 1.0m head of water (i.e. vertical orientation) of **2.39 LPS / m width⁴**
 - Hydraulic flow capacity under 0.1 m head of water (i.e. horizontal orientation) of **0.645 LPS / m width⁵**

The review compared the structural and hydraulic loads for each application to the structural and hydraulic capacity to determine if DELTA®-TERRAXX is suitable for use in the various applications.

1. Positive Side Foundation Wall Waterproofing

DELTA®-TERRAXX is used in open cut foundation wall applications where it is installed on the exterior side of the foundation waterproofing system. In this application DELTA®-TERRAXX is subjected to lateral soil pressure loads as well as hydraulic loads due to water percolating through the soil which is drained vertically to foundation weeping tiles (or down to the water table) through the DELTA®-TERRAXX. Based on a 3-story deep open cut foundation and a water table occurring at a 2-story depth, DELTA®-TERRAXX is suitable for use in this application.

FIGURE 1: Positive Side Foundation Wall Waterproofing

DELTA®-TERRAXX
Compressive Capacity
PASS (33% max)

Compressive Load (kPa)
142 kN/m²
(2,967 psf)

DELTA®-TERRAXX
Hydraulic Capacity
PASS (9% max)

Hydraulic Load (LPS / m)
0.21 LPS / m

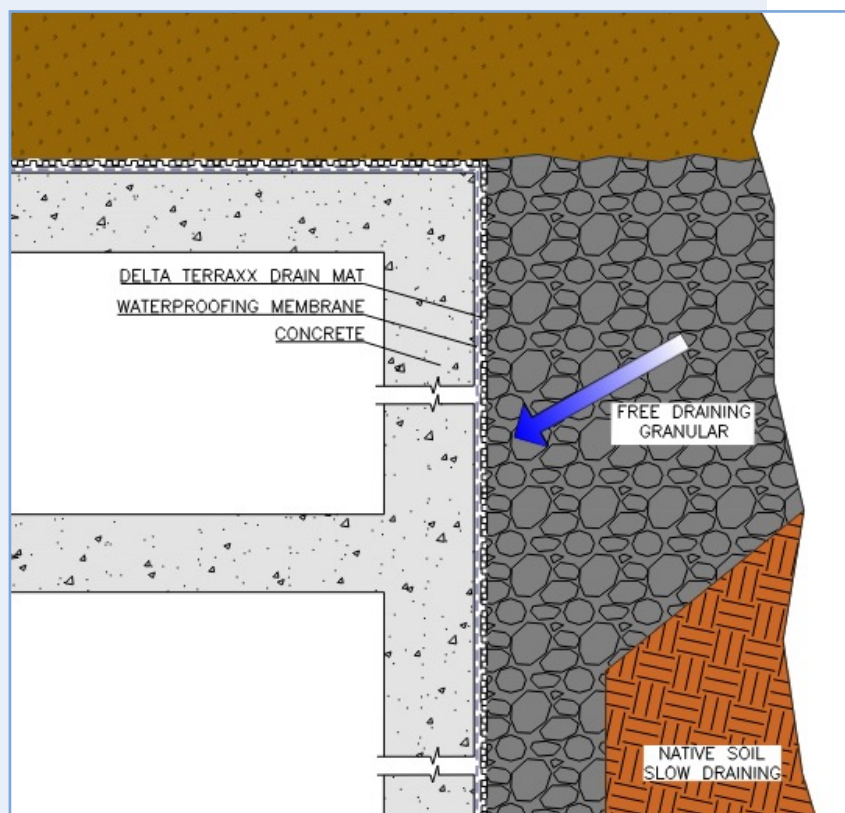

Lateral soil pressures at various depths were calculated by $\sigma = K_a \gamma h + q K_a - 2 C \sqrt{K_a}$; with the following conservative assumptions: 12m depth (3-story), Non cohesive soil, Angle of friction (Φ) 25°, Bulk unit weight (γ) 25 kN/m³, Adjacent building surcharge (q) 50 kN/m², Rankine Earth pressure coefficient (K_a) based on angle of friction 0.41.

Hydraulic Loads were calculated by OBC 2012 - 4.1.7.3 and the National Plumbing Code with the following assumptions: 6m Depth to water table, 6m Distance to drain from podium, 6m Distance to drain from landscaping, flow converges in DELTA®-TERRAXX at 6m depth, 15 Min Rainfall = 28mm (London). Flow rate is Litres per second per metre width of DELTA®-TERRAXX. Hydraulic Load in DELTA®-TERRAXX = Podium Deck Waterproofing - Traffic Areas flow, plus 10% of total surface load of landscaping reflecting slow percolation rate.

2. Blindside Foundation Wall Waterproofing

DELTA®-TERRAXX is used in soil retained foundation wall applications where it is installed on the interior side of the soil support system (timber lagging or caisson wall) prior to installation of the foundation waterproofing system. In this application DELTA®-TERRAXX is subjected to lateral soil pressure loads as well as hydraulic loads due to water percolating through the soil and soil support system which is drained vertically to foundation weeping tiles (or down to the water table) through the DELTA®-TERRAXX. Based on a 7-story deep open cut foundation and a water table occurring at a 2-story depth, DELTA®-TERRAXX is suitable for use in this application.

FIGURE 2: Blindside Foundation Wall Waterproofing

DELTA®-TERRAXX
Compressive Capacity
PASS (71% max)

Compressive Load (kPa)
304 kN/m²
(6,357 psf)

DELTA®-TERRAXX
Hydraulic Capacity
PASS (9% max)

Hydraulic Load (LPS / m)
0.21 LPS / m

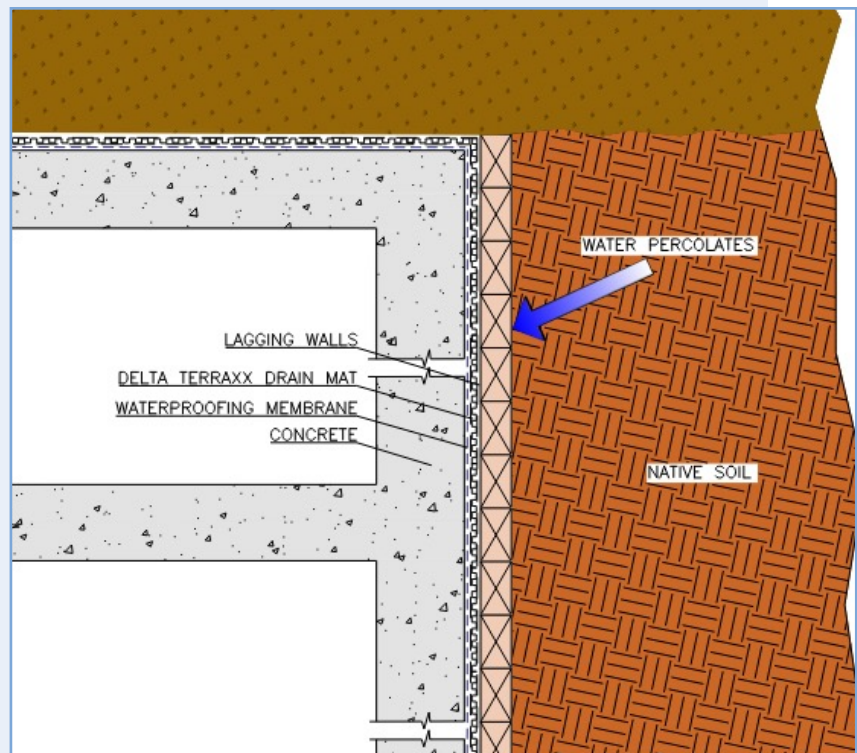

Lateral soil pressures at various depths were calculated by $\sigma = K_a \gamma h + q K_a - 2 C \sqrt{K_a}$; with the following conservative assumptions: 28m depth (7-story), Non cohesive soil, Angle of friction (Φ) 25°, Bulk unit weight (γ) 25 kN/m³, Adjacent building surcharge (q) 50 kN/m², Rankine Earth pressure coefficient (K_a) based on angle of friction 0.41.

Hydraulic Loads were calculated by OBC 2012 - 4.1.7.3 and the National Plumbing Code with the following assumptions: 6m Depth to water table, 6m Distance to drain from podium, 6m Distance to drain from landscaping, flow converges in DELTA®-TERRAXX at 6m depth, 15 Min Rainfall = 28mm (London). Flow rate is Litres per second per metre width of DELTA®-TERRAXX. Hydraulic Load in DELTA®-TERRAXX = Podium Deck Waterproofing - Traffic Areas flow, plus 10% of total surface load of landscaping reflecting slow percolation rate.

3. Occupied Inverted Roof Terrace

DELTA®-TERRAXX is used in PMRA (Protected Membrane Roof Assembly) or inverted roof applications where it is installed on top of the roof membrane system and below the insulation and surface pavers. In this application DELTA®-TERRAXX is subjected to vertical loads from roofing pavers, snow loads, and pedestrian loads in the case of an occupied terrace. DELTA®-TERRAXX is also subjected to hydraulic loads due to rainwater, passing through surface pavers, which is drained horizontally to roof drains through the DELTA®-TERRAXX. Based on an occupied terrace assembly DELTA®-TERRAXX is suitable for use in this application.

FIGURE 3: Occupied Inverted Roof Terrace

**DELTA®-TERRAXX
Compressive Capacity
PASS (1% max)**

**Compressive Load (kPa)
4.9 kN/m²
(90 psf)**

**DELTA®-TERRAXX
Hydraulic Capacity
PASS (98% x-machine)**

**Hydraulic Load (LPS / m)
0.63 LPS / m**

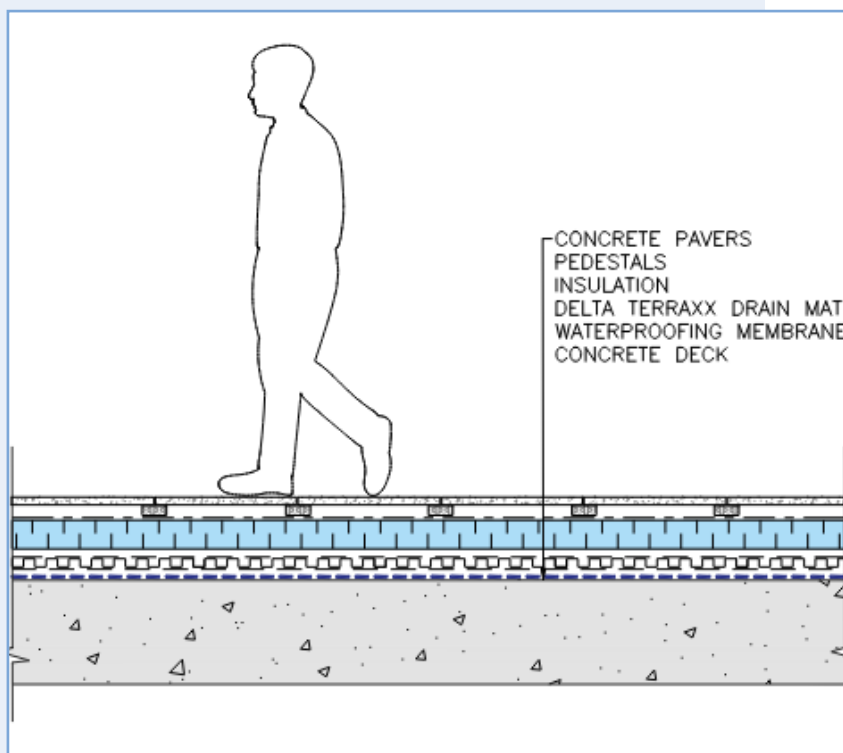

Vertical loads were calculated with the following assumptions: Inverted roof with continuous pedestrian paver surface 1.16 kN/m², snow loads 1.36 kN/m², live load for occupied terrace 2.40 kN/m².

Hydraulic Loads were calculated by OBC 2012 - 4.1.7.3 and the National Plumbing Code with the following assumptions: 900m² Drainage area, 22m Distance to drain, 2% slope, 15 Min Rainfall = 28mm (London). Flow rate is Litres per second per metre width of DELTA®-TERRAXX. Hydraulic Load in DELTA®-TERRAXX = 50% of total surface load per "Hydraulic Characterization and Design of Permeable Interlocking Concrete", Kevern et al 2015.

4. Green Roof – Unoccupied – Extensive

DELTA®-TERRAXX is used in green roof applications where it is installed on top of the roof membrane system (conventional assembly) or on top of the insulation (PMRA assembly) and below the green roof growing media and surface plantings. In this application, DELTA®-TERRAXX is subjected to vertical loads from green roof and snow loads but not from pedestrian loads as these extensive systems are not occupied. DELTA®-TERRAXX is also subjected to hydraulic loads due to rainwater, passing through green roof growing media and plantings, which is drained horizontally to roof drains through the DELTA®-TERRAXX. Based on an unoccupied extensive green roof assembly DELTA®-TERRAXX is suitable for use in this application.

FIGURE 4: Green Roof – Unoccupied – Extensive

DELTA®-TERRAXX
Compressive Capacity
PASS (1% max)

Compressive Load (kPa)
3.5 kN/m²
(73 psf)

DELTA®-TERRAXX
Hydraulic Capacity
PASS (39% x-machine)

Hydraulic Load (LPS / m)
0.25 LPS / m

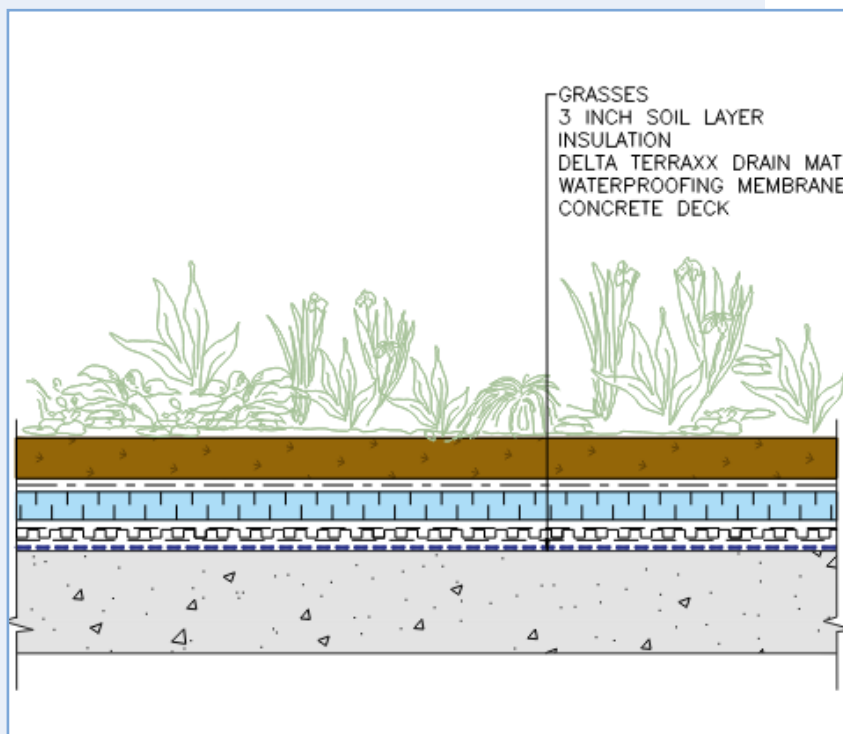

Vertical loads were calculated with the following assumptions: Extensive green roof, 75mm saturated growing medium 1.14 kN/m², snow loads 1.36 kN/m², live load 1.0 kN/m².

Hydraulic Loads were calculated by OBC 2012 - 4.1.7.3 and the National Plumbing Code with the following assumptions: 900m² Drainage area, 22m Distance to drain, 2% slope, 15 Min Rainfall = 28mm (London). Flow rate is Litres per second per metre width of DELTA®-TERRAXX. Hydraulic Load in DELTA®-TERRAXX = 20% of total surface load per published 50% water retention of extensive assembly.

5. Podium Deck Waterproofing – Landscaped Areas

DELTA®-TERRAXX is used in podium deck waterproofing assemblies under landscaped areas (or intensive green roof assemblies) where it is installed on top of the horizontal podium deck waterproofing (or green roof membrane) system. DELTA®-TERRAXX is typically installed below the landscaping soil (or intensive green roof growing media) on top of insulation (if applicable). In this application, DELTA®-TERRAXX is subjected to vertical loads from landscaping soil and plantings, snow loads, and limited pedestrian loads. DELTA®-TERRAXX is also subjected to hydraulic loads due to rainwater, passing through the soil and plantings, which is drained horizontally to roof drains (or to podium downturns) through the DELTA®-TERRAXX. Based on a podium deck waterproofing assembly under landscaped areas, DELTA®-TERRAXX is suitable for use in this application.

FIGURE 5: Podium Deck Waterproofing – Landscaping or Intensive Green Roof

DELTA®-TERRAXX
Compressive Capacity
PASS (1% max)

Compressive Load (kPa)
3.5 kN/m²
(73 psf)

DELTA®-TERRAXX
Hydraulic Capacity
PASS (39% x-machine)

Hydraulic Load (LPS / m)
0.25 LPS / m

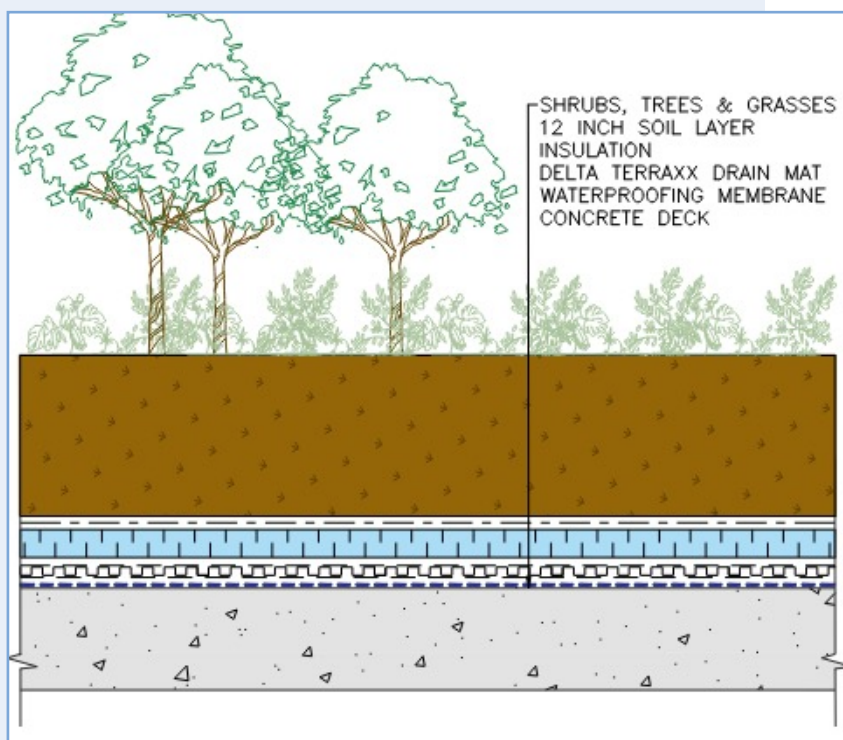

Vertical loads were calculated with the following assumptions: Intensive green roof or landscaped podium, 300mm saturated growing medium 4.53 kN/m², snow loads 1.36 kN/m², live load 1.0 kN/m².

Hydraulic Loads were calculated by OBC 2012 - 4.1.7.3 and the National Plumbing Code with the following assumptions: 900m² Drainage area, 22m Distance to drain, 2% slope, 15 Min Rainfall = 28mm (London). Flow rate is Litres per second per metre width of DELTA®-TERRAXX. Hydraulic Load in DELTA®-TERRAXX = 20% of total surface load.

6. Podium Deck Waterproofing – Traffic Areas

DELTA®-TERRAXX is used in podium deck waterproofing assemblies under traffic areas where it is installed on top of the horizontal podium deck waterproofing system. DELTA®-TERRAXX is typically installed below the traffic bearing pavement assembly on top of insulation (if applicable). In this application, DELTA®-TERRAXX is subjected to vertical loads from snow loads, and significant vehicle wheel point loads. DELTA®-TERRAXX is also subjected to hydraulic loads due to rainwater, passing through the soil and plantings, which is drained horizontally to roof drains (or to podium downturns) through the DELTA®-TERRAXX. Based on a podium deck waterproofing assembly under traffic areas, DELTA®-TERRAXX is suitable for use in this application.

FIGURE 6: Podium Deck Waterproofing – Traffic Areas

**DELTA®-TERRAXX
Compressive Capacity
PASS (66% max)**

**Compressive Load (kPa)
280 kN/m²
(5,850 psf)**

**DELTA®-TERRAXX
Hydraulic Capacity
PASS (98% x-machine)**

**Hydraulic Load (LPS / m)
0.63 LPS / m**

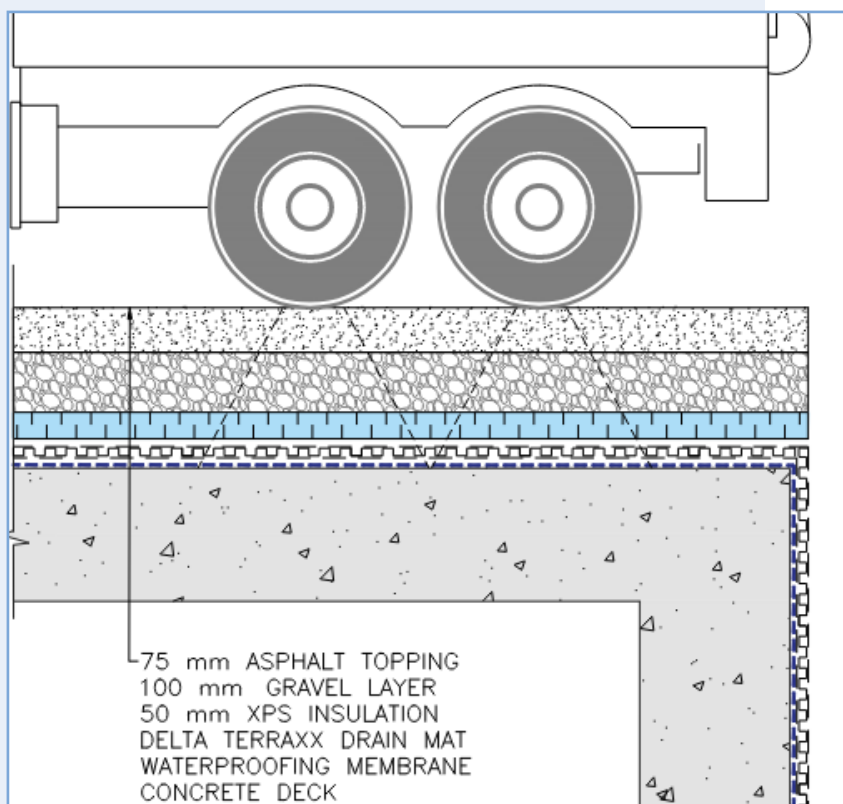

Vertical loads were calculated with the following assumptions: Pervious traffic paver assembly at minimum 150mm thickness near drain 3.03 kN/m², snow loads 1.36 kN/m², tandem truck wheel point load 276 kN/m².

Hydraulic Loads were calculated by OBC 2012 - 4.1.7.3 and the National Plumbing Code with the following assumptions: 900m² Drainage area, 22m Distance to drain, 2% slope, 15 Min Rainfall = 28mm (London). Flow rate is Litres per second per metre width of DELTA®-TERRAXX. Hydraulic Load in DELTA®-TERRAXX = 50% of total surface load per "Hydraulic Characterization and Design of Permeable Interlocking Concrete", Kevren et al 2015.

Summary

MH has completed the review of the suitability of DELTA®-TERRAXX as a drainboard in several common waterproofing applications. DELTA®-TERRAXX by Dörken Systems is suitable for use in all six (6) of the applications analyzed. The structural compressive strength of DELTA®-TERRAXX exceeds the structural loads in all applications analyzed. The hydraulic capacity of DELTA®-TERRAXX exceeds the hydraulic loads in all applications analyzed. The results are summarized in the following table.

APPLICATION	Compressive Load (kPa / psf)	Compressive Capacity (pass/fail)	Hydraulic Load (LPS / m)	Hydraulic Capacity (pass/fail)
Positive Side Waterproofing 3 Story Deep	142 2,970	PASS 429 8,969	0.21	PASS 2.39 (9%)
Blindside Waterproofing 7 Story Deep	304 6,360	PASS 429 8,969	0.21	PASS 2.39 (9%)
Inverted Roof Occupied Terrace	4.9 103	PASS 429 8,969	0.63	PASS 0.645 (98%)
Green Roof Unoccupied Extensive	3.5 73	PASS 429 8,969	0.25	PASS 0.645 (39%)
Podium Deck Waterproofing Non-traffic	7.1 148	PASS 429 8,969	0.25	PASS 0.645 (39%)
Podium Deck Waterproofing Traffic Loads	280 5,850	PASS 429 8,969	0.63	PASS 0.645 (98%)
MAXIMUMS	304 6,360 psf	PASS (71%)	0.63	PASS (98%)

Closing

In our professional opinion the compressive strength of DELTA®-TERRAXX is suitable for use in vertical waterproofing systems up to 7 stories below grade, and in horizontal waterproofing systems including under typical traffic loads.

Sincerely,

Morrison Hershfield Limited

A handwritten signature in blue ink, appearing to read "S Murray", with a long horizontal flourish extending to the right.

Steven Murray, P.Eng.
Director, Building Science
Building Specialty Services

¹ Analysis Report 4208-0805-1A, SCC Accreditation No.: 40, prepared by SAGEOS, dated October 12, 2022.

² Analysis Report 4208-0805-1A, SCC Accreditation No.: 40, prepared by SAGEOS, dated October 12, 2022.

³ Analysis Report 4208-0805-1A, SCC Accreditation No.: 40, prepared by SAGEOS, dated October 12, 2022.

⁴ Analysis Report 4208-0835-4A, SCC Accreditation No.: 40, prepared by SAGEOS, dated January 9, 2023.

⁵ Analysis Report 4208-0835-4A, SCC Accreditation No.: 40, prepared by SAGEOS, dated January 9, 2023.

DELTA[®]-TERRAXX Drainboard Bulletin

LONG-TERM DRAINAGE PERFORMANCE

One of the challenges designers face when selecting drainboard is that the water flow rates claimed on technical data sheets are often not representative of the actual in-service drainage performance of the products. This is because during service, the soil pressure against the drainboard deflects the geotextile into the drainage space created by the dimples, thereby reducing the in-plane water flow rate.

Dörken completed third party testing of drainboard products available in the market using a modified ASTM D4716M-22 test, with one rigid plate and one sand plate to be more reflective of actual in service conditions. The modified testing at 3,759 lbf/ft² and 1.0 hydraulic gradient* found a 20-78% reduction in water flow rate amongst other drainboards in the market. One drainboard claimed a flow rate of ~21 gal/min/ft but only achieved ~5 gal/min/ft when tested, a 78% reduction in flow rate when in service.

The required compressive strength of drainboard depends on its application and the type of assembly it is used in.

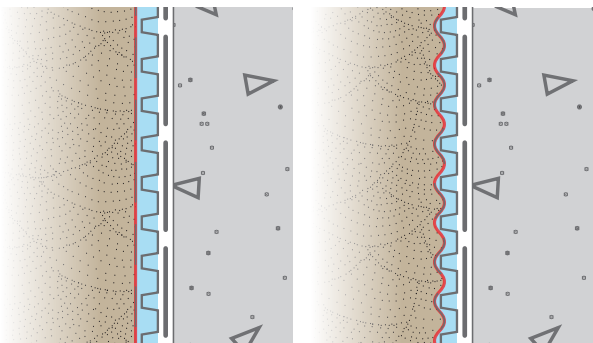

Drainage core without geotextile deflection

Reduced drainage core width from geotextile deflection

DELTA[®]-TERRAXX has a compressive strength of 8,500 lbf/ft² which is appropriate for a wide range of residential and commercial building assemblies, such as the following:

* Hydraulic gradient refers to the rate of change in total head per unit distance of flow in a particular direction.

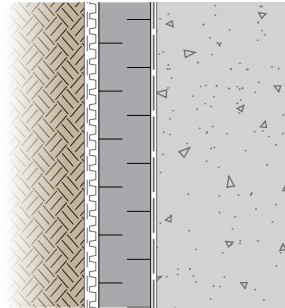

Below-grade Walls
(See table on last page)

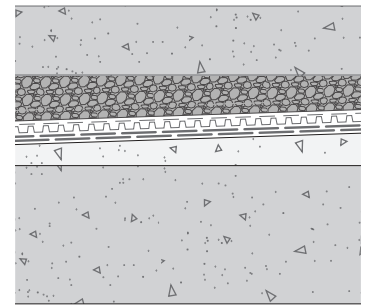

Vehicular Access Roofs
(with concentrated live load up to 8,000 lbf on an area of 5" x 5")

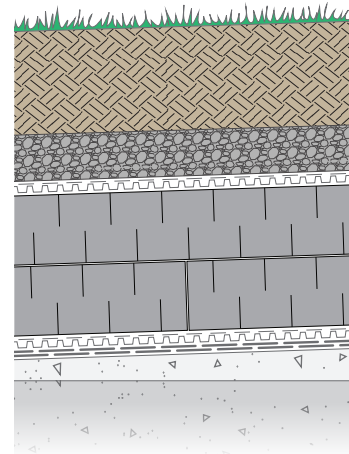

Green Roofs
(Extensive, Intensive and Deep)

HIGH-PERFORMANCE MATERIALS

DELTA[®]-TERRAXX drainboard drainage core is made from high-density polyethylene (HDPE), a stable and inorganic plastic. While still providing the needed compressive strength for many applications, DELTA[®]-TERRAXX drainage core is more malleable than most competitors making it extremely easy to handle and cut. The fully bonded non-woven polypropylene geotextile filter fabric allows water to pass into the drainage core but limits the passage of soil particles to ensure long-term drainage capacity.

INSTALLER FRIENDLY DESIGN

DELTA®-TERRAXX by Dörken is designed with ease of installation in mind. These are some key features and properties that result in a quick and easy installation.

1 SELF-ADHERING EDGE

DELTA®-TERRAXX comes with a self-adhering drainage core edge, for a better, faster, and easier sealing of drainboard laps. Both the self-adhering drainage core edge and cantilevered geotextile can be sealed to achieve a continuous drainage core, that prevents backfill material from trickling in. High performance tape can also be used to effectively seal the geotextile filter fabric at butt edges.

2 WIDER AND LIGHTER ROLLS

DELTA®-TERRAXX is available in 6.58' wide rolls, making it wider than most competitors 6' wide rolls. Larger rolls means fewer rolls required for a project and less laps that require sealing, speeding up the installation process. Additionally, due to the lighter material, the wider rolls are lighter and easier to handle than competing products.

3 Workability

DELTA®-TERRAXX relaxes easily when unrolled on a flat surface, speeding up the installation process and reducing the need to temporarily hold down loose drain board on horizontal applications like roofs.

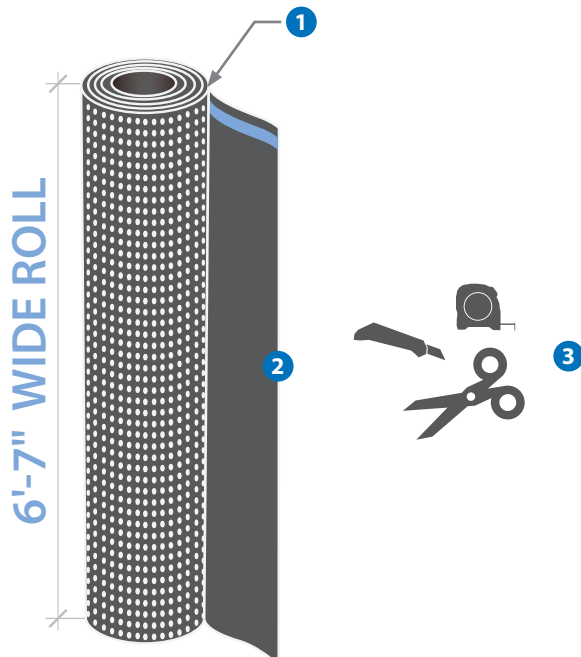

FUTURE-PROOF FLOW RATES TO PROTECT YOUR BUILDING

Buildings, and especially drainage systems, need to be future proof and resilient to the affects of climate change. This climate change resilience supports the need for higher flow rates, long-term drainage capacity, and reliable in-plane water flow rates.

For example, the southern United States is hotter and wetter than ever before. Temperatures in Houston, Texas have increased 0.6-1.0 °F and annual rainfall increased by ~2" compared to the previous 30-year averages. Extreme precipitation events are also on the rise. Each Houston county experienced less than 3 days of rain over 3" in the 1980s, but in the 2010s experienced 12-17 days.

Designers select drainboards assuming 100% of the claimed flow rate on technical data sheets but under real world conditions only achieve 22-80% of the claimed flow rate. This gap between the assumed and in-service flow rate can result in under-sized drainage systems that are already less than increasingly extreme precipitation events require, which may result in damage to below grade structures or roofs, and unexpected cost/inconvenience to the owners & occupants.

Observed Change in Total Annual Precipitation Falling in the Heaviest 1% of Events*

(1901-2016)

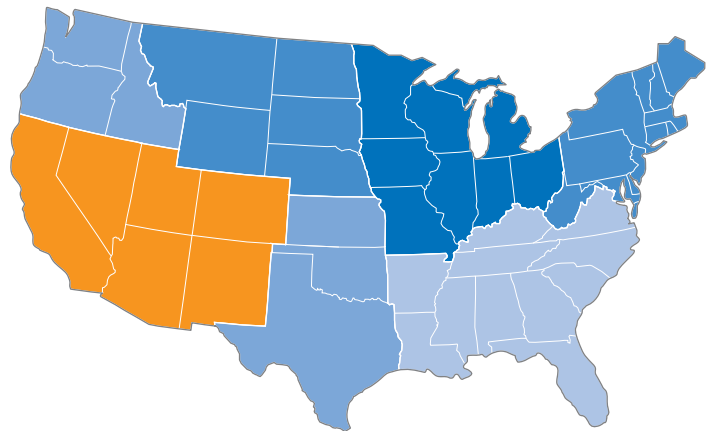

* Map adapted from the National Climate Assessment Climate Science Special Report, and the US Global Change Research Program's Indicator Platform

BELOW-GRADE VERTICAL APPLICATION DESIGN TABLE

Maximum soil depths permitted with DELTA®-TERRAXX drainboard for different soil types.

	Φ (deg)	K_0	γ (lbf/ft ³)	q (lbf/ft ²)	h (ft)	Factored Lateral Pressure (lbf/ft ²)
Sand	30	0.5	121	250	45	4250
Compacted Gravel	35	0.43	127	250	50	4250

The values provided in the table above are for general guidance only. Obtain soil specific properties from a geotechnical engineer for a specific location including anticipated lateral pressures on retaining walls. Maximum soil depths can generally be confirmed using the following calculation method.

Lateral soil pressure (P) = $K_0 \cdot (\gamma \cdot h + q)$

- Angle of friction (Φ) used to calculate K_0
- Bulk unit weight (γ)
- Soil depth (h)
- Adjacent heavy truck surcharge (q) = 250 lbf/ft²
- Earth pressure coefficient (K_0) based on angle of friction (Φ) and at rest condition
- No lateral water pressure is allowed for as the drainage mat relieves water pressure
- Level backfill assumed

Note: The values of angle of friction, earth pressure coefficient, bulk unit weight, and adjacent surcharge mentioned in the table above are assumed based on general design purposes.

DISCLAIMER

Information provided in this technical bulletin is for general guidance. Design and installation of appropriate drainboard and building enclosure assemblies, both for structural capacity and drainage capacity, remains the responsibility of the project team.

PERFORMANCE BACKED BY SCIENCE

RDH Building Science Laboratories has conducted thorough testing on our DELTA®-TERRAXX drainboard using the ASTM D4716M-22 Standard testing Method. This report details the observed performance and benefits of our next-generation drainboard.

ABOUT RDH

RDH Building Science Laboratories provides a range of research, testing, and education services, breaking down complex data to enable informed decision making based on science.



References

National Centers for Environmental Information.
National Oceanic and Atmospheric Administration
(NOAA). U.S. Climate Normals.

2021 International Building Code (2021 IBC).
International Code Council.

ASTM D4716M-22 Standard test Method for
Determining the (In-plane) Flow Rate per Unit Width
and Hydraulic Transmissivity of a Geo-synthetic
Using a Constant Head. ASTM International

Dörken Systems Inc.
4655 Delta way, Beamsville, ON L3J 0T6, Canada
Tel: 1 888 433 5824 | www.dorken.com

DELTA®-TERRAXX

Powerful protection and drainage for deck and below grade wall waterproofing

Health and Safety

- Required safety equipment: hard hat, safety boots, gloves and safety glasses.
- Always follow all safety precautions as directed by the Occupational Safety and Health Administration (OSHA-USA) or the Construction Safety Association (Canada).
- Please refer to Safety Data Sheets for all components and observe all recommended safety precautions therein.
- The general codes of practice for protection at work and instructions of the manufacturers for tools and components are to be observed at all times.

Recommended Materials

- DELTA®-TERRAXX
- DELTA®-FAST'ners
- DELTA®-MULTIBAND Tape

Recommended Tools

- Utility knife
- Measuring tape
- Hammer or nail gun

Recommended fasteners when fastening in the field of membrane

- Galvanized nails with flat heads.

Installation

- The installation instructions for DELTA®-TERRAXX are intended only as a guide and are for the convenience of contractors, specifiers, and other interested parties. The final application and details are the sole responsibility of the design authority on record for the project.
- Installers must have experience installing drainage composites with a minimum of 5 projects (recommended).
- Ensure protrusions that may penetrate the membrane are removed from substrate.

Podium Deck Drainage Composite Applications (flat surfaces, roofs, etc)

- Roll out membrane onto a waterproofed substrate with geotextile facing upward towards the overburden (cup side down, fabric side up).
- At end laps, strip back the geotextile of adjoining layer. Cut back the core of the DELTA®-TERRAXX by 4" (100 mm). Butt to the adjacent layer, overlapping the geotextile only. Do not interlock the dimples.
- At side laps with the self-adhering flat tab, place the subsequent course on the flat tab of the previous course with the dimples butted together. Remove the release liner from the adhesive strip and press the sheets together, ensuring intimate contact between the drainboard and the adhesive strip. Overlap the excess fabric onto the adjoining sheet to keep out soil particulate.
- Install sheets without gaps, wrinkles, creases, or tears.

Foundation Wall Drainage Composite Applications (Positive Side):

- Install drainage composite with flat side against wall, geotextile facing the soil, and over waterproofing. When installed vertically, drainage composite should be installed starting at the anticipated grade level down to footing, and in other locations as indicated by construction plans.
- When installing horizontally, start at lowest point and work to top, running it the length of the sheets, and draping over the top of the footing.
- Position the first row of DELTA®-FAST'ners 8" (200 mm) below the top of DELTA®-TERRAXX. Fasten drainage composite using DELTA®-FAST'ners with concrete nails in a "W" pattern 12" (305 mm) o/c. Distance between rows should be 4" to 6" (100 mm to 150 mm).

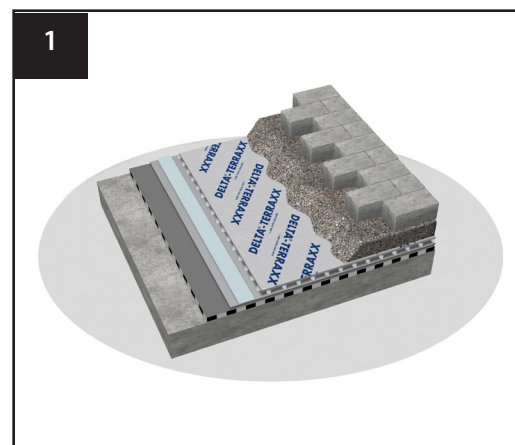

- If the membrane is installed vertically, at end laps, overlap the drainage composite by 6" (150 mm) in a downward shingle fashion. Do not interlock the dimples.
- If the membrane is being installed horizontally, at end laps, strip back the geotextile of the adjoining layer. Cut back the core of the DELTA®-TERRAXX by 4" (100 mm). Butt to the adjacent layer, overlapping the geotextile only. Do not interlock the dimples. Fasten in place with DELTA®-FAST'ners at 8" (305 mm) o/c along overlap.
- At side laps with the self-adhering flat tab, place the subsequent course on the flat tab of the previous course with the dimples butted together. Remove the release liner from the adhesive strip and press the sheets together, ensuring intimate contact between the drainboard and the adhesive strip. Overlap the excess fabric onto the adjoining sheet to keep out soil particulate.
- Install sheets without gaps, wrinkles, creases, or tears.
- Fold the fabric over the top edge and fasten 8" on center.

Blind Side Applications (Negative Side):

- On lagging, pile, or earth forms, and other "blind" wall construction, install drainage composite with geotextile in contact with soil retention system.
- Seal butt joints without the flat tab and adhesive strip on core side of drainage composite continuously with 4" (100 mm) DELTA®-MULTI BAND tape.
- At joints with the flat tab and adhesive strip, butt edges, place the subsequent course on the flat tab of the previous course with the dimples butted together. Remove the release liner from the adhesive strip and press the sheets together, ensuring intimate contact between the two drainboards.
- Overlap the geotextile in a shingle fashion to prevent soil particulates from entering the air gap, potentially clogging the drainage core.
- Joints with the self-adhering flat tab do not require additional tape.
- Use galvanized nails. Nail length will vary depending upon the surface to which the prefabricated drain is being attached. Galvanized nails should have flat heads, and washers or wood strapping may be used to prevent the nail head from being driven through the drainage composite.
- Fold the fabric over the top edge and fasten 8" on center.
- At end laps, cut back the core of the DELTA®-TERRAXX by 4" (100 mm). Fold the remaining geotextile in a manner designed to keep soil particulate from entering the air gap. Fasten in place 8" (200 mm) o/c.

For technical support, call our Technical Support Team at 1-888-433-5824 extension 326, or visit www.dorken.com

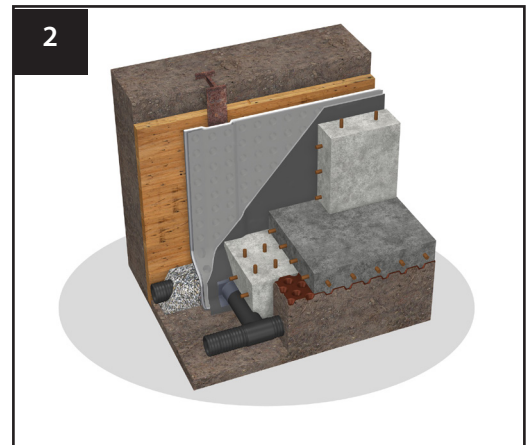



Note: gravel not shown for clarity

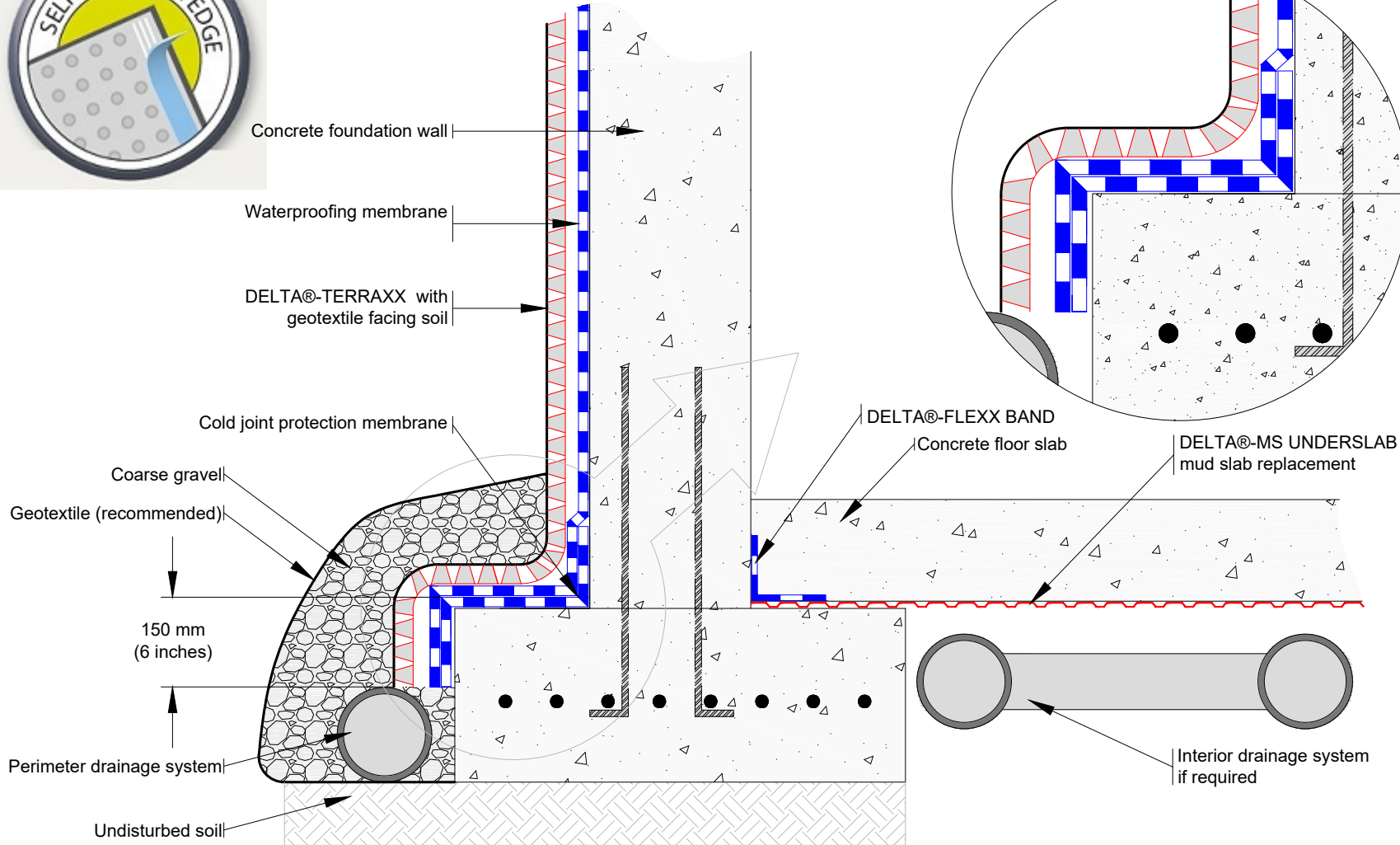

SUBSTANTIAL EFFORT HAS BEEN MADE TO ENSURE THAT THE INFORMATION IN THIS DETAIL DRAWING IS ACCURATE. COSELLA-DÖRKEN PRODUCTS INC. CANNOT ACCEPT RESPONSIBILITY FOR ANY ERRORS OR OVERSIGHTS IN THE USE OF THIS MATERIAL OR IN THE PREPARATION OF ARCHITECTURAL OR ENGINEERING PLANS. THE DESIGN PROFESSIONAL MUST RECOGNIZE THAT NO DESIGN DETAIL CAN SUBSTITUTE FOR EXPERIENCED ENGINEERING AND PROFESSIONAL JUDGEMENT.

TITLE:

DELTA®-TERRAXX WITH FOUNDATION WALL AND FLOOR SLAB AT FOOTING LEVEL

DRAWN BY: Krzysztof Apriasz C. Tech., CPHC®

DATE: November 15, 2022
SCALE: NTS

FILE NAME:
DTERRAXX_1



DELTA®



Note: gravel not shown for clarity

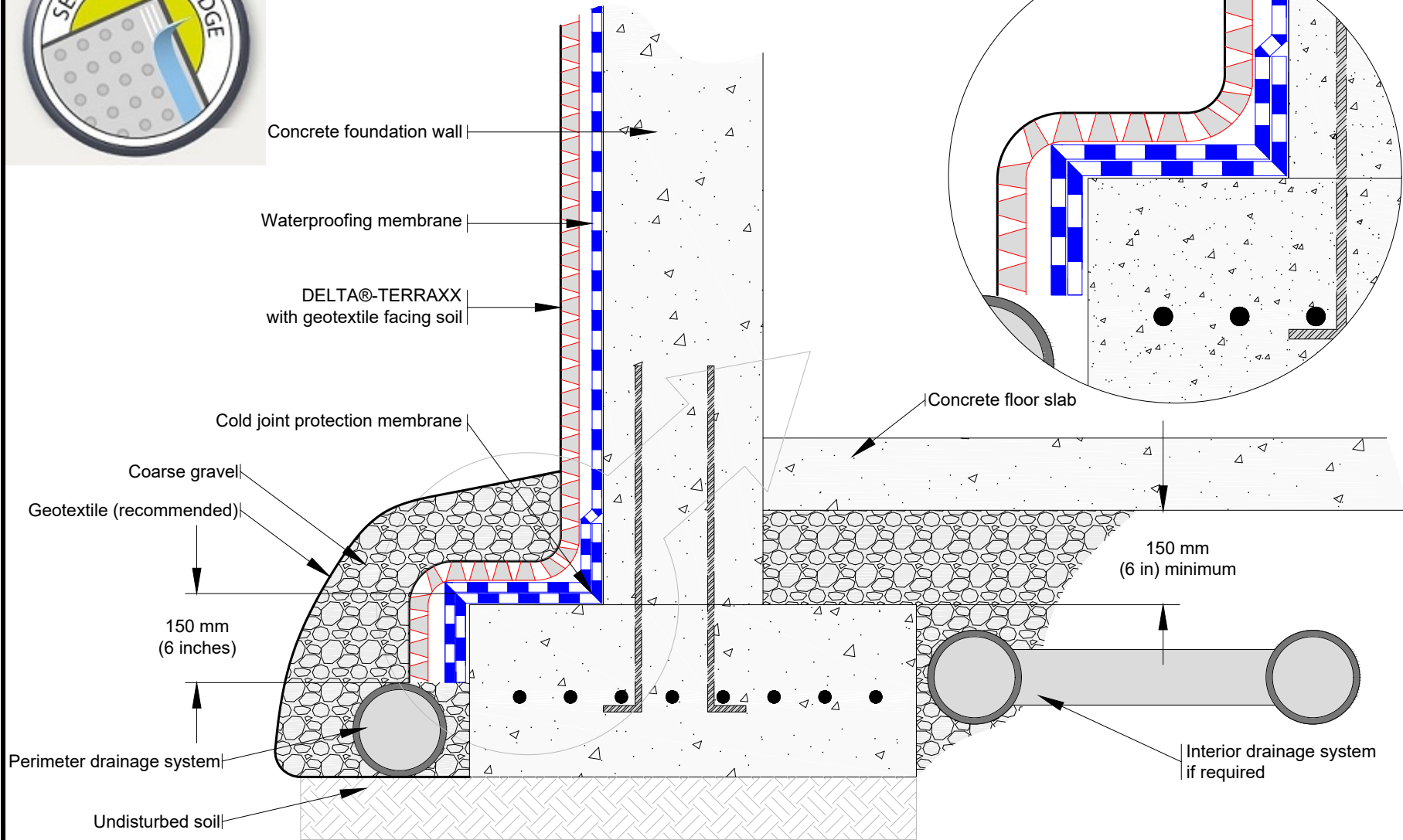

SUBSTANTIAL EFFORT HAS BEEN MADE TO ENSURE THAT THE INFORMATION IN THIS DETAIL DRAWING IS ACCURATE. DÖRKEN SYSTEMS INC. CANNOT ACCEPT RESPONSIBILITY FOR ANY ERRORS OR OVERSIGHTS IN THE USE OF THIS MATERIAL OR IN THE PREPARATION OF ARCHITECTURAL OR ENGINEERING PLANS. THE DESIGN PROFESSIONAL MUST RECOGNIZE THAT NO DESIGN DETAIL CAN SUBSTITUTE FOR EXPERIENCED ENGINEERING AND PROFESSIONAL JUDGEMENT.

TITLE:

DELTA®-TERRAXX WITH FOUNDATION WALL AND ELEVATED FLOOR SLAB

DRAWN BY: Krzysztof Apriasz C. Tech., CPHC®

DATE: November 15, 2022
SCALE: NTS

FILE NAME:
DTERRAXX_2



DELTA®



Note: gravel not shown for clarity

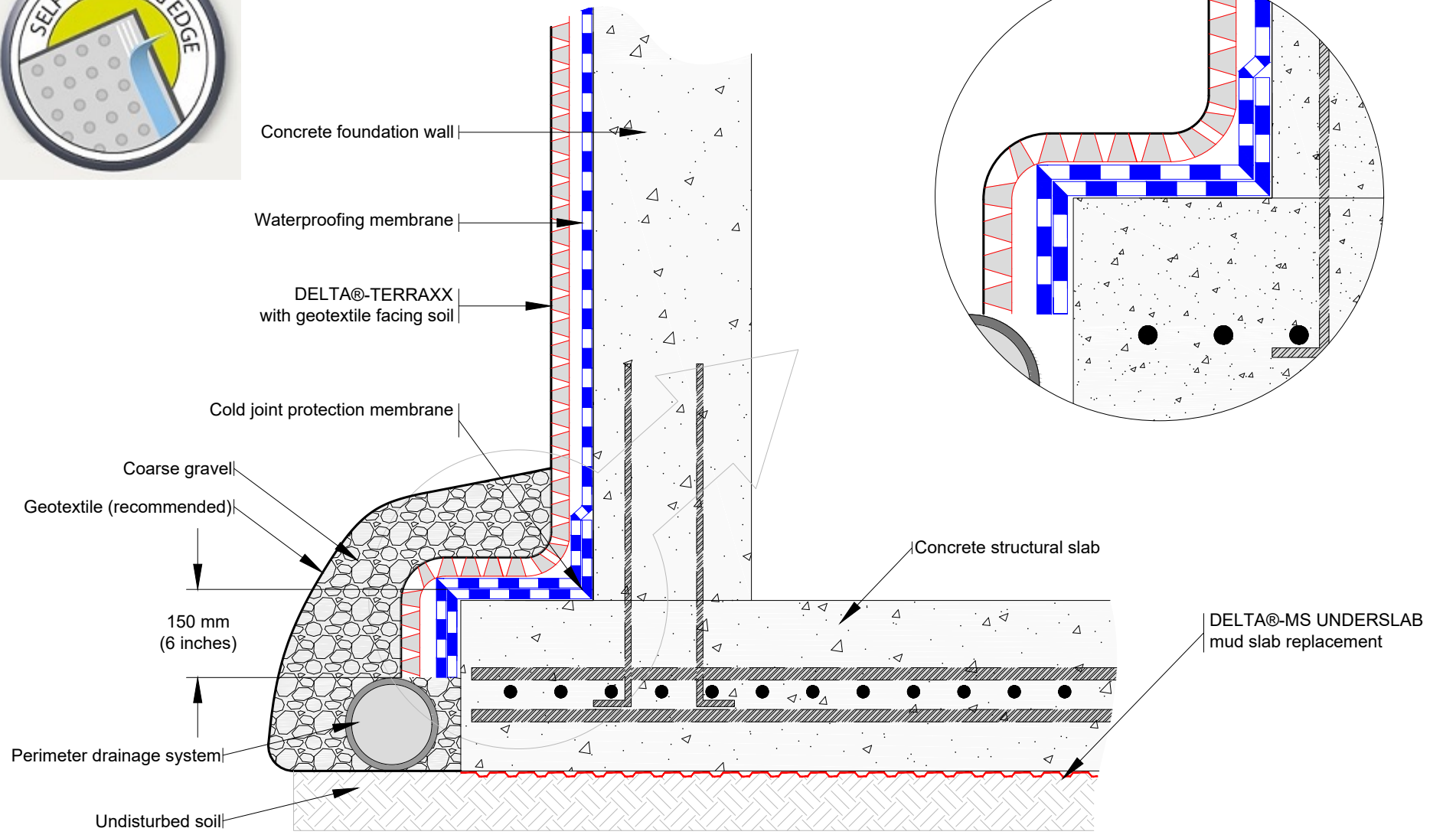

SUBSTANTIAL EFFORT HAS BEEN MADE TO ENSURE THAT THE INFORMATION IN THIS DETAIL DRAWING IS ACCURATE. DÖRKEN SYSTEMS INC. CANNOT ACCEPT RESPONSIBILITY FOR ANY ERRORS OR OVERSIGHTS IN THE USE OF THIS MATERIAL OR IN THE PREPARATION OF ARCHITECTURAL OR ENGINEERING PLANS. THE DESIGN PROFESSIONAL MUST RECOGNIZE THAT NO DESIGN DETAIL CAN SUBSTITUTE FOR EXPERIENCED ENGINEERING AND PROFESSIONAL JUDGEMENT.

TITLE:

DELTA®-TERRAXX WITH FOUNDATION WALL ON STRUCTURAL SLAB

DRAWN BY: Krzysztof Apriasz C. Tech., CPHC®

DATE: November 15, 2022
SCALE: NTS

FILE NAME:
DTERRAXX_3



DELTA®

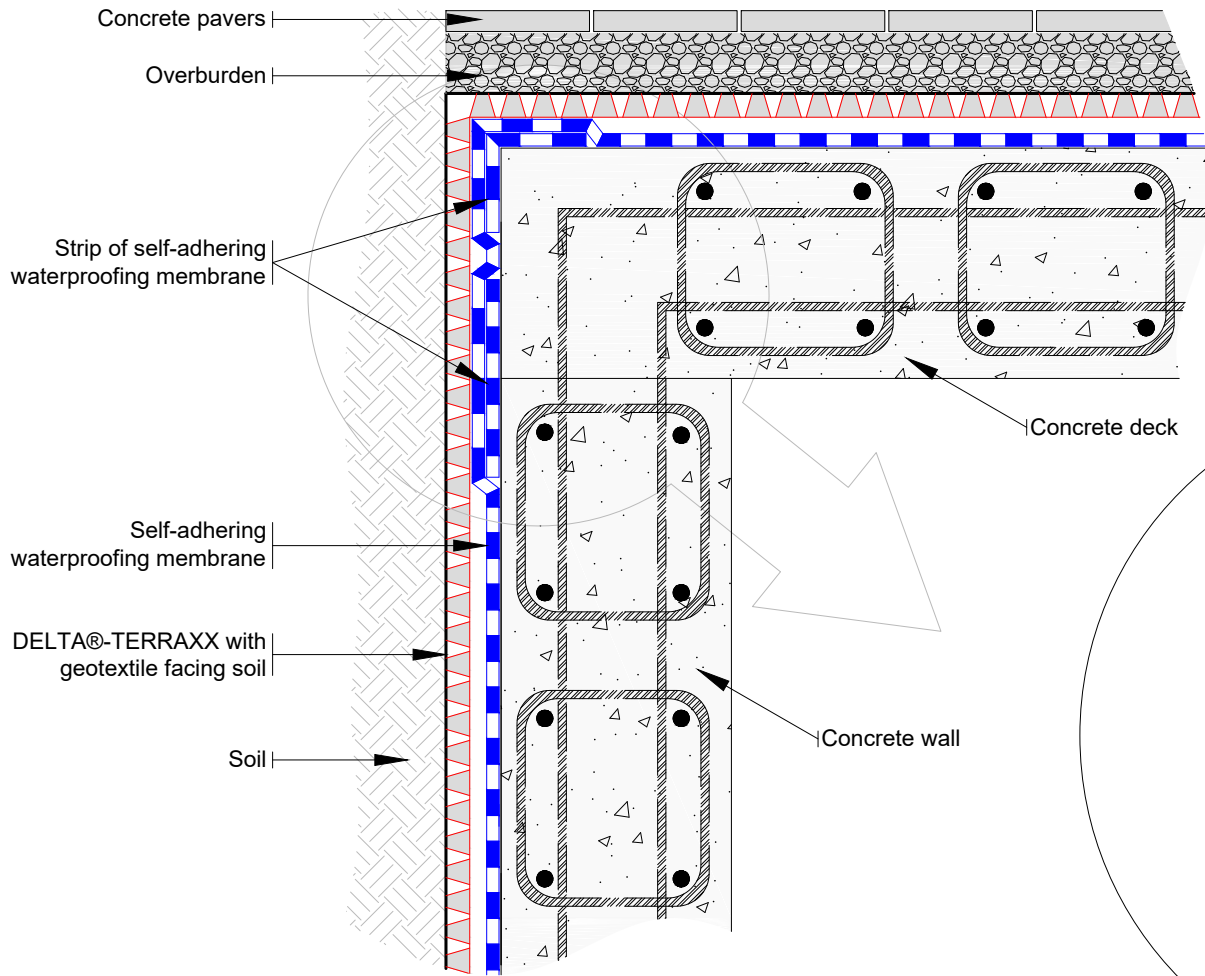

Strip of self-adhering waterproofing membrane

Self-adhering waterproofing membrane

DELTA®-TERRAXX with geotextile facing soil

Soil

Concrete deck

Concrete wall



Note: soil and pavers not shown for clarity

SUBSTANTIAL EFFORT HAS BEEN MADE TO ENSURE THAT THE INFORMATION IN THIS DETAIL DRAWING IS ACCURATE. DÖRKEN SYSTEMS INC. CANNOT ACCEPT RESPONSIBILITY FOR ANY ERRORS OR OVERSIGHTS IN THE USE OF THIS MATERIAL OR IN THE PREPARATION OF ARCHITECTURAL OR ENGINEERING PLANS. THE DESIGN PROFESSIONAL MUST RECOGNIZE THAT NO DESIGN DETAIL CAN SUBSTITUTE FOR EXPERIENCED ENGINEERING AND PROFESSIONAL JUDGEMENT.

TITLE:

DELTA®-TERRAXX WITH PLAZA DECK TO WALL TIE-IN DETAIL

DRAWN BY: Krzysztof Apriasz C. Tech., CPHC®

DATE: November 15, 2022
SCALE: NTS

FILE NAME:
DTERRAXX_4



DELTA®

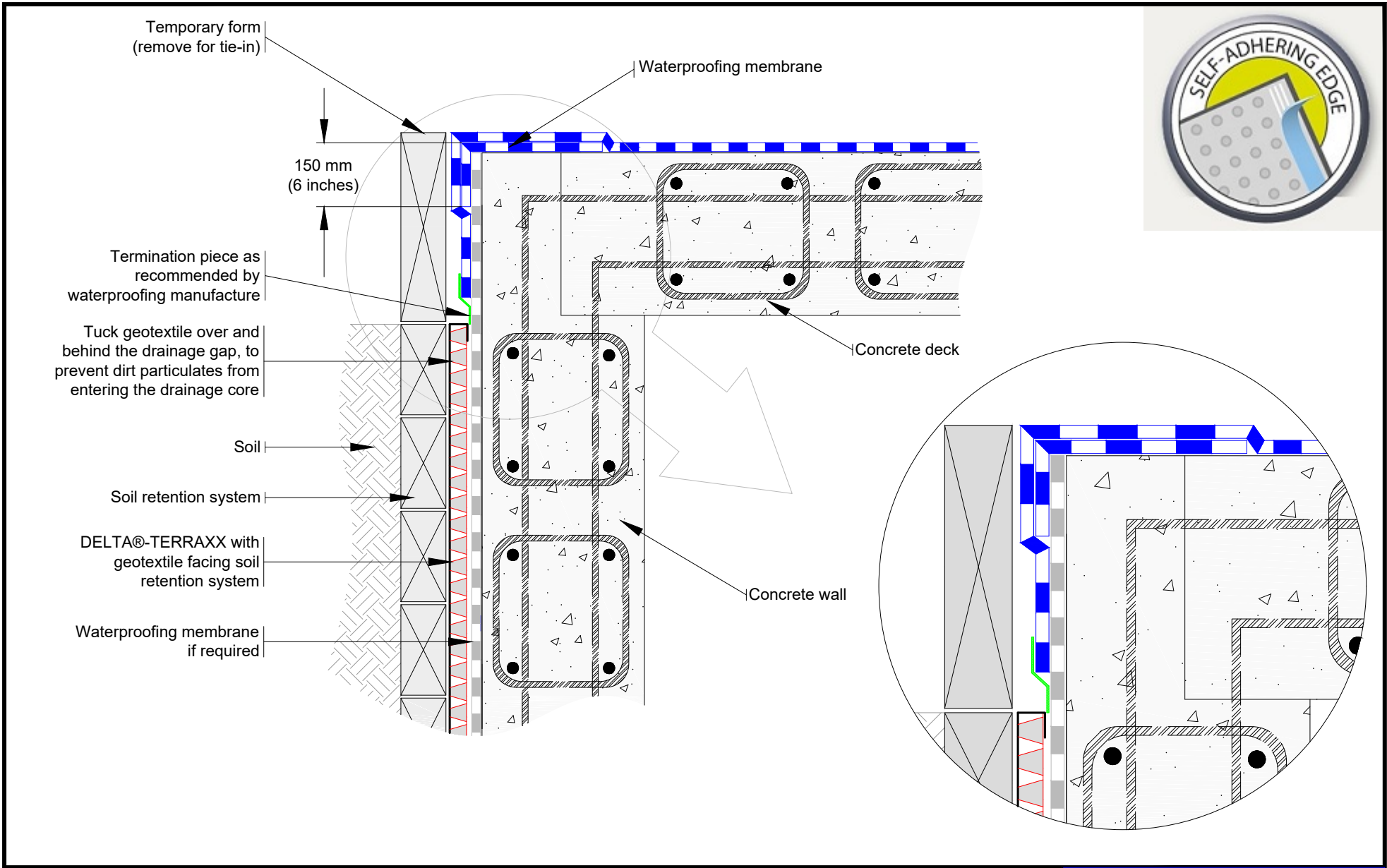

SUBSTANTIAL EFFORT HAS BEEN MADE TO ENSURE THAT THE INFORMATION IN THIS DETAIL DRAWING IS ACCURATE. DÖRKEN SYSTEMS INC. CANNOT ACCEPT RESPONSIBILITY FOR ANY ERRORS OR OVERSIGHTS IN THE USE OF THIS MATERIAL OR IN THE PREPARATION OF ARCHITECTURAL OR ENGINEERING PLANS. THE DESIGN PROFESSIONAL MUST RECOGNIZE THAT NO DESIGN DETAIL CAN SUBSTITUTE FOR EXPERIENCED ENGINEERING AND PROFESSIONAL JUDGEMENT.

TITLE:
**DELTA®-TERRAXX with PLAZA DECK
 WATERPROOFING TIE-IN TO
 VERTICAL BLIND SIDE WATERPROOFING DETAIL**

DRAWN BY:
 Krzysztof Apiaasz C. Tech., CPHC®

DATE: February 17, 2017
 SCALE: NTS

FILE NAME:
 DTERRAXX_5



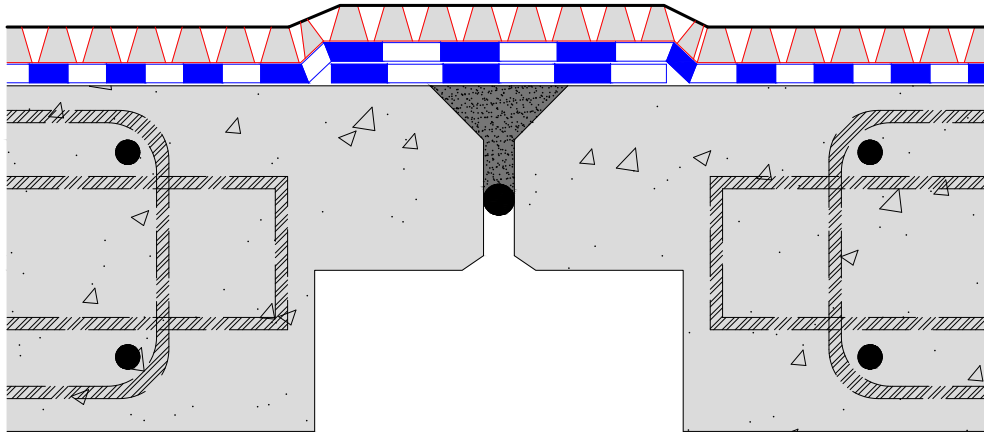

Note: For joint where movement is expected (active joints) see expansion joint cover detail



Note: Typical DELTA®-TERRAXX overlap

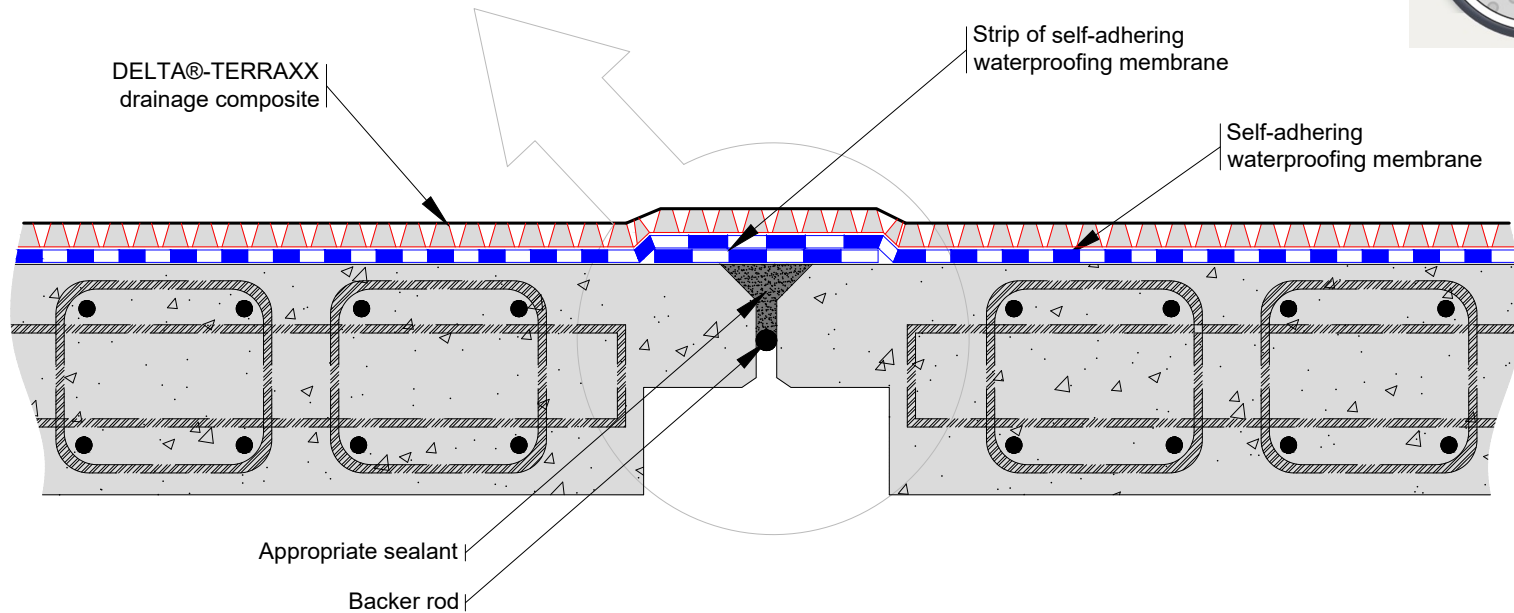

SUBSTANTIAL EFFORT HAS BEEN MADE TO ENSURE THAT THE INFORMATION IN THIS DETAIL DRAWING IS ACCURATE. DÖRKEN SYSTEMS INC. CANNOT ACCEPT RESPONSIBILITY FOR ANY ERRORS OR OVERSIGHTS IN THE USE OF THIS MATERIAL OR IN THE PREPARATION OF ARCHITECTURAL OR ENGINEERING PLANS. THE DESIGN PROFESSIONAL MUST RECOGNIZE THAT NO DESIGN DETAIL CAN SUBSTITUTE FOR EXPERIENCED ENGINEERING AND PROFESSIONAL JUDGEMENT.

TITLE:

DELTA®-TERRAXX WITH PASSIVE JOINT COVER DETAIL

DRAWN BY: Krzysztof Apriasz C. Tech., CPHC®

DATE: November 15, 2022
SCALE: NTS

FILE NAME:
DTERRAXX_6

 **DÖRKEN**

DELTA®

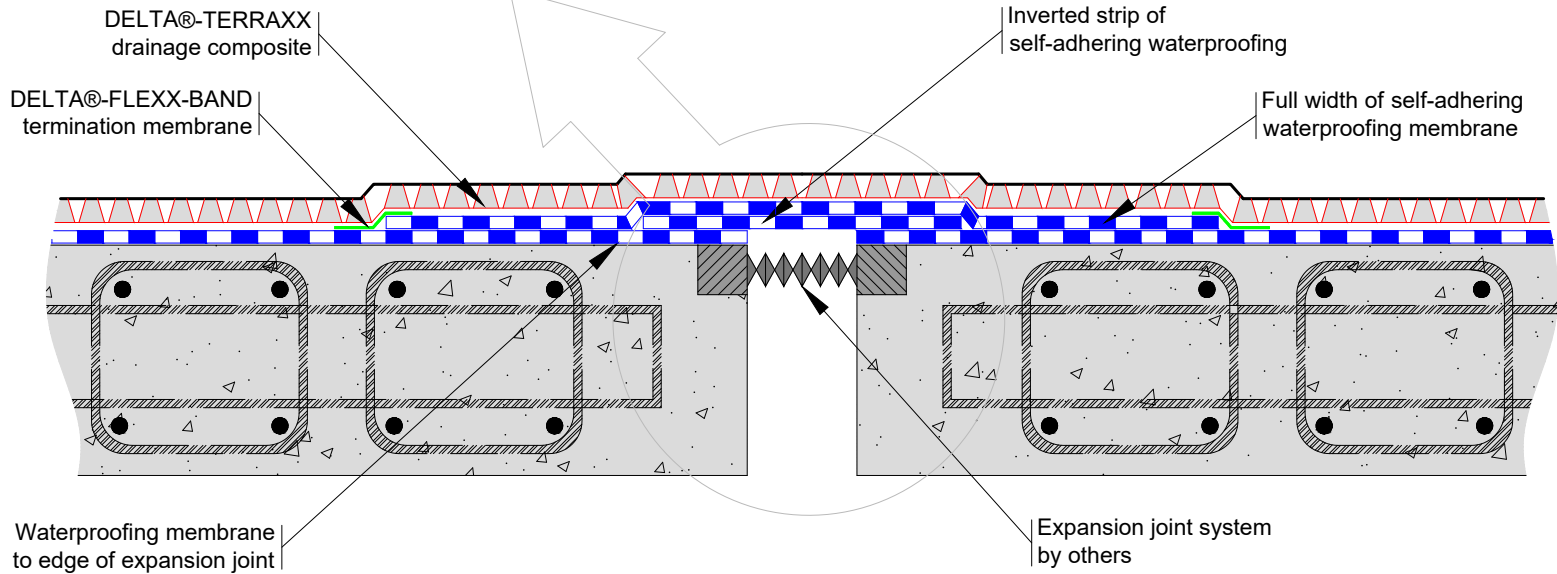
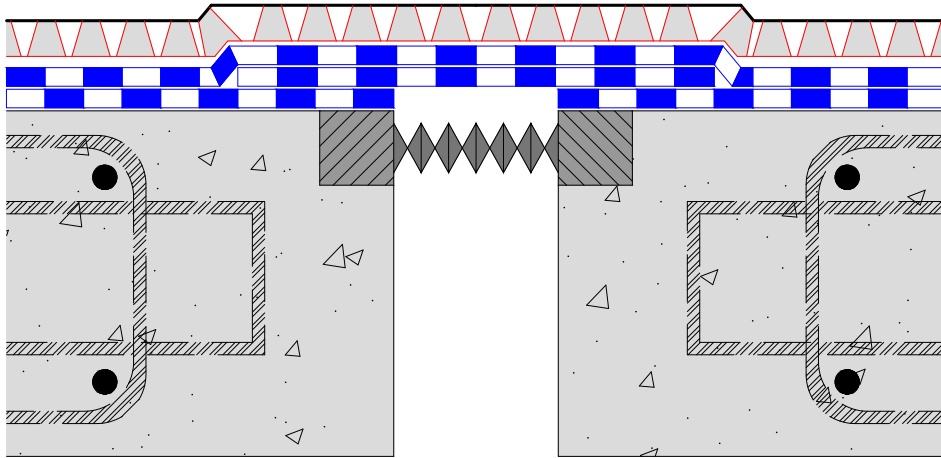

SUBSTANTIAL EFFORT HAS BEEN MADE TO ENSURE THAT THE INFORMATION IN THIS DETAIL DRAWING IS ACCURATE. DÖRKEN SYSTEMS INC. CANNOT ACCEPT RESPONSIBILITY FOR ANY ERRORS OR OVERSIGHTS IN THE USE OF THIS MATERIAL OR IN THE PREPARATION OF ARCHITECTURAL OR ENGINEERING PLANS. THE DESIGN PROFESSIONAL MUST RECOGNIZE THAT NO DESIGN DETAIL CAN SUBSTITUTE FOR EXPERIENCED ENGINEERING AND PROFESSIONAL JUDGEMENT.

TITLE:

**DELTA®-TERRAXX WITH EXPANSION
JOINT COVER DECK DETAIL WITH
MOVEMENT LESS THAN 13 mm ($\frac{1}{2}$ INCHES)**

DRAWN BY: Krzysztof Apriasz C. Tech., CPHC®

DATE: November 15, 2022
SCALE: NTS

FILE NAME:
DTERRAXX_7



DELTA®

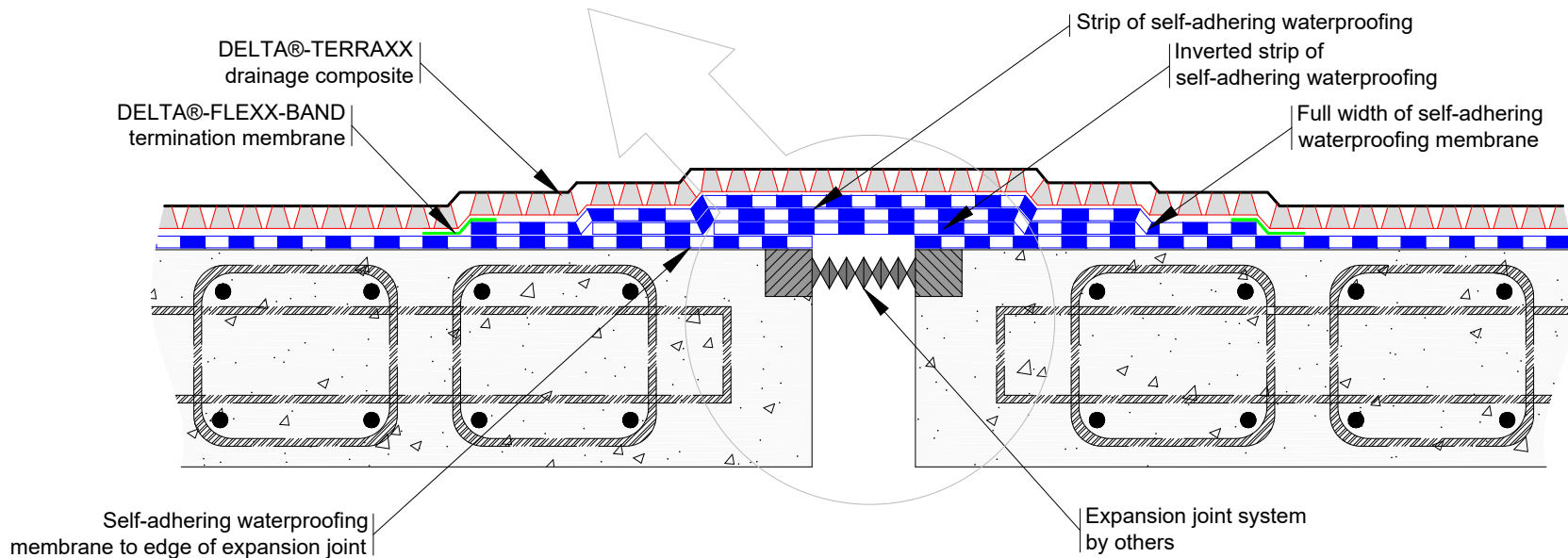
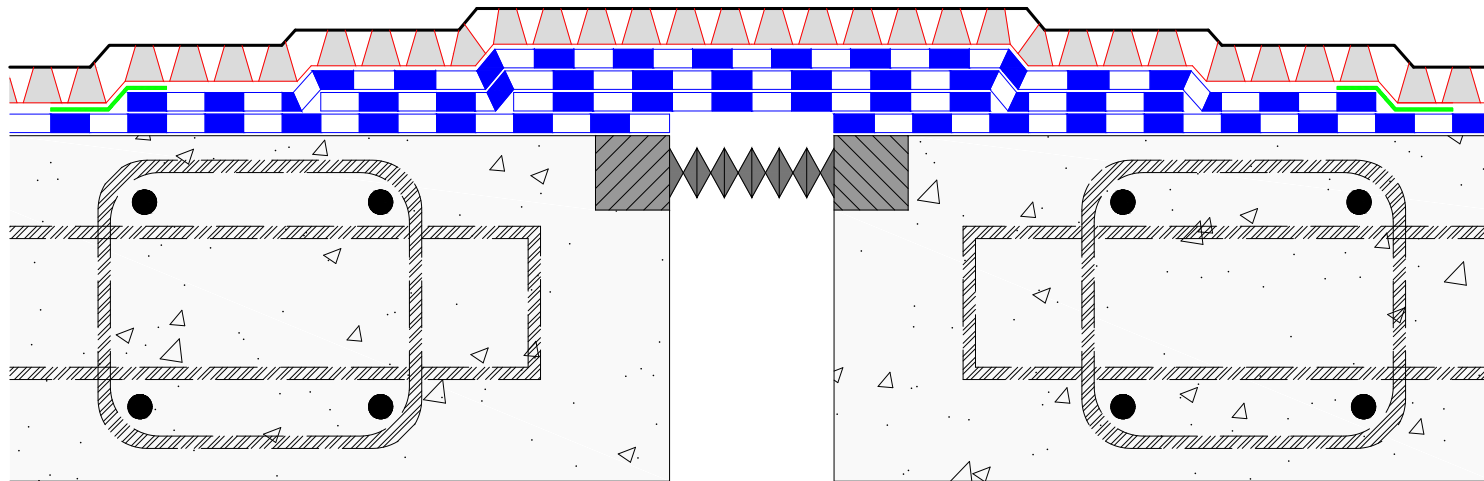

SUBSTANTIAL EFFORT HAS BEEN MADE TO ENSURE THAT THE INFORMATION IN THIS DETAIL DRAWING IS ACCURATE. DÖRKEN SYSTEMS INC. CANNOT ACCEPT RESPONSIBILITY FOR ANY ERRORS OR OVERSIGHTS IN THE USE OF THIS MATERIAL OR IN THE PREPARATION OF ARCHITECTURAL OR ENGINEERING PLANS. THE DESIGN PROFESSIONAL MUST RECOGNIZE THAT NO DESIGN DETAIL CAN SUBSTITUTE FOR EXPERIENCED ENGINEERING AND PROFESSIONAL JUDGEMENT.

TITLE:

**DELTA®-TERRAXX WITH EXPANSION JOINT
COVER DECK DETAIL WITH MOVEMENT**

MORE THAN 13 mm (1/2 INCHES)

DRAWN BY: Krzysztof Apriasz C. Tech., CPHC®

DATE: November 15, 2022
SCALE: NTS

FILE NAME:
DTERRAXX_8



DELTA®

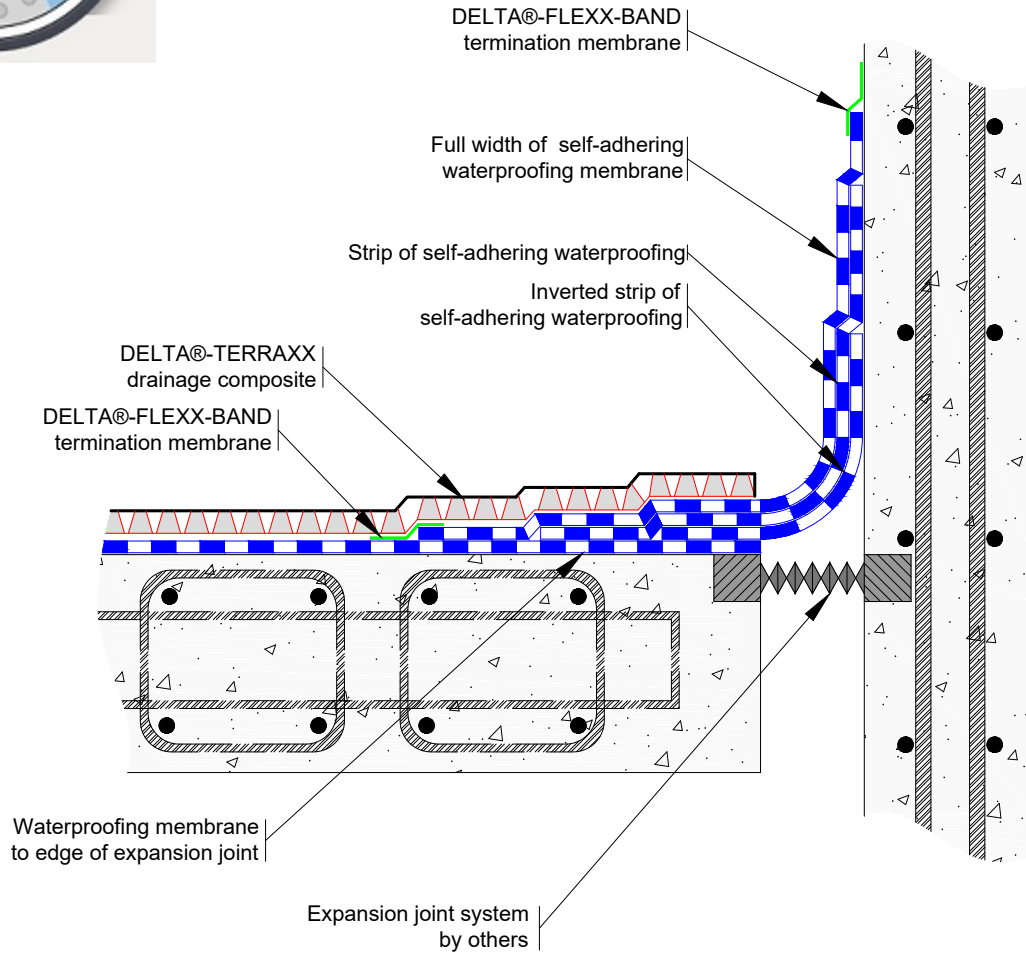

SUBSTANTIAL EFFORT HAS BEEN MADE TO ENSURE THAT THE INFORMATION IN THIS DETAIL DRAWING IS ACCURATE. DÖRKEN SYSTEMS INC. CANNOT ACCEPT RESPONSIBILITY FOR ANY ERRORS OR OVERSIGHTS IN THE USE OF THIS MATERIAL OR IN THE PREPARATION OF ARCHITECTURAL OR ENGINEERING PLANS. THE DESIGN PROFESSIONAL MUST RECOGNIZE THAT NO DESIGN DETAIL CAN SUBSTITUTE FOR EXPERIENCED ENGINEERING AND PROFESSIONAL JUDGEMENT.

TITLE:

**DELTA®-TERRAXX
EXPANSION JOINT COVER
DECK TO WALL JUNCTION DETAIL**

DRAWN BY: Krzysztof Apiasz C. Tech., CPHC®

Date: November 16, 2022

File Name: DTERRAXX_09



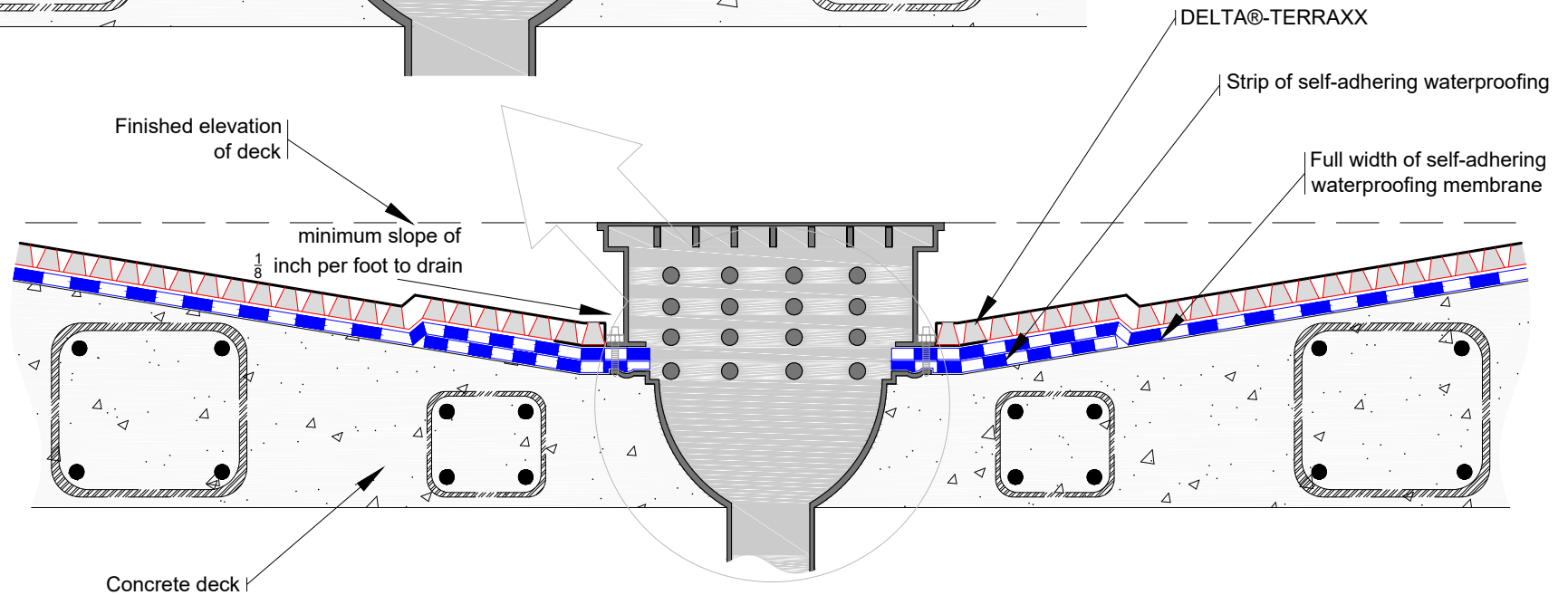
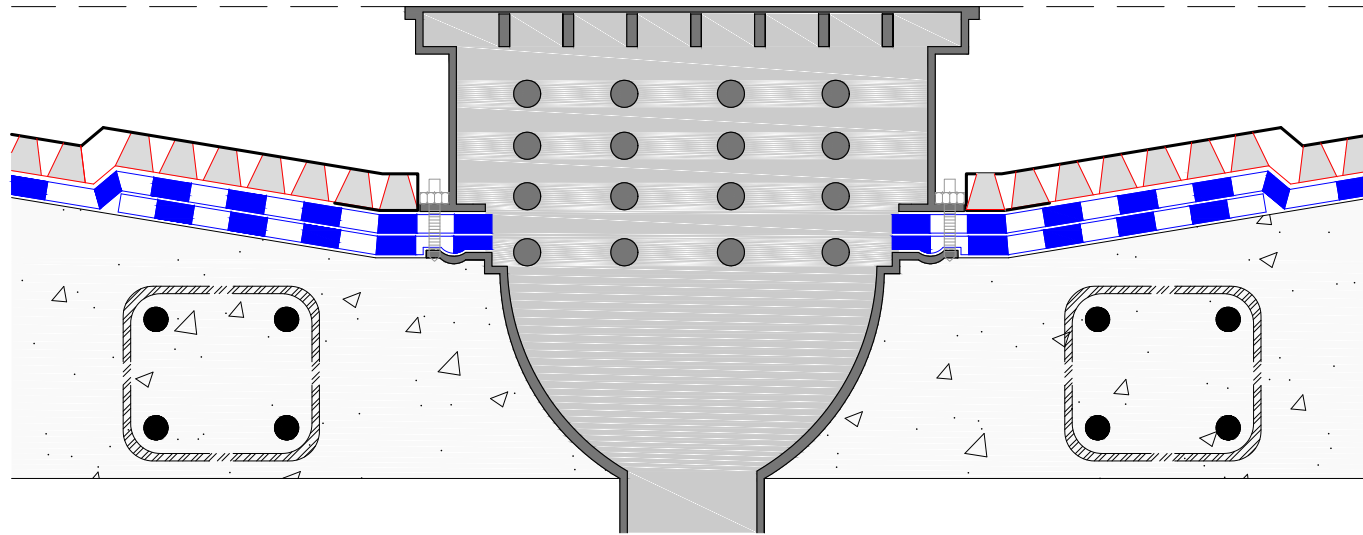

SUBSTANTIAL EFFORT HAS BEEN MADE TO ENSURE THAT THE INFORMATION IN THIS DETAIL DRAWING IS ACCURATE. DÖRKEN SYSTEMS INC. CANNOT ACCEPT RESPONSIBILITY FOR ANY ERRORS OR OVERSIGHTS IN THE USE OF THIS MATERIAL OR IN THE PREPARATION OF ARCHITECTURAL OR ENGINEERING PLANS. THE DESIGN PROFESSIONAL MUST RECOGNIZE THAT NO DESIGN DETAIL CAN SUBSTITUTE FOR EXPERIENCED ENGINEERING AND PROFESSIONAL JUDGEMENT.

TITLE:

DELTA®-TERRAXX WITH TYPICAL DRAIN DETAIL

DRAWN BY: Krzysztof Apriasz C. Tech., CPHC®

DATE: November 16, 2022
SCALE: NTS

FILE NAME:
DTERRAXX_10

 **DÖRKEN**

DELTA®

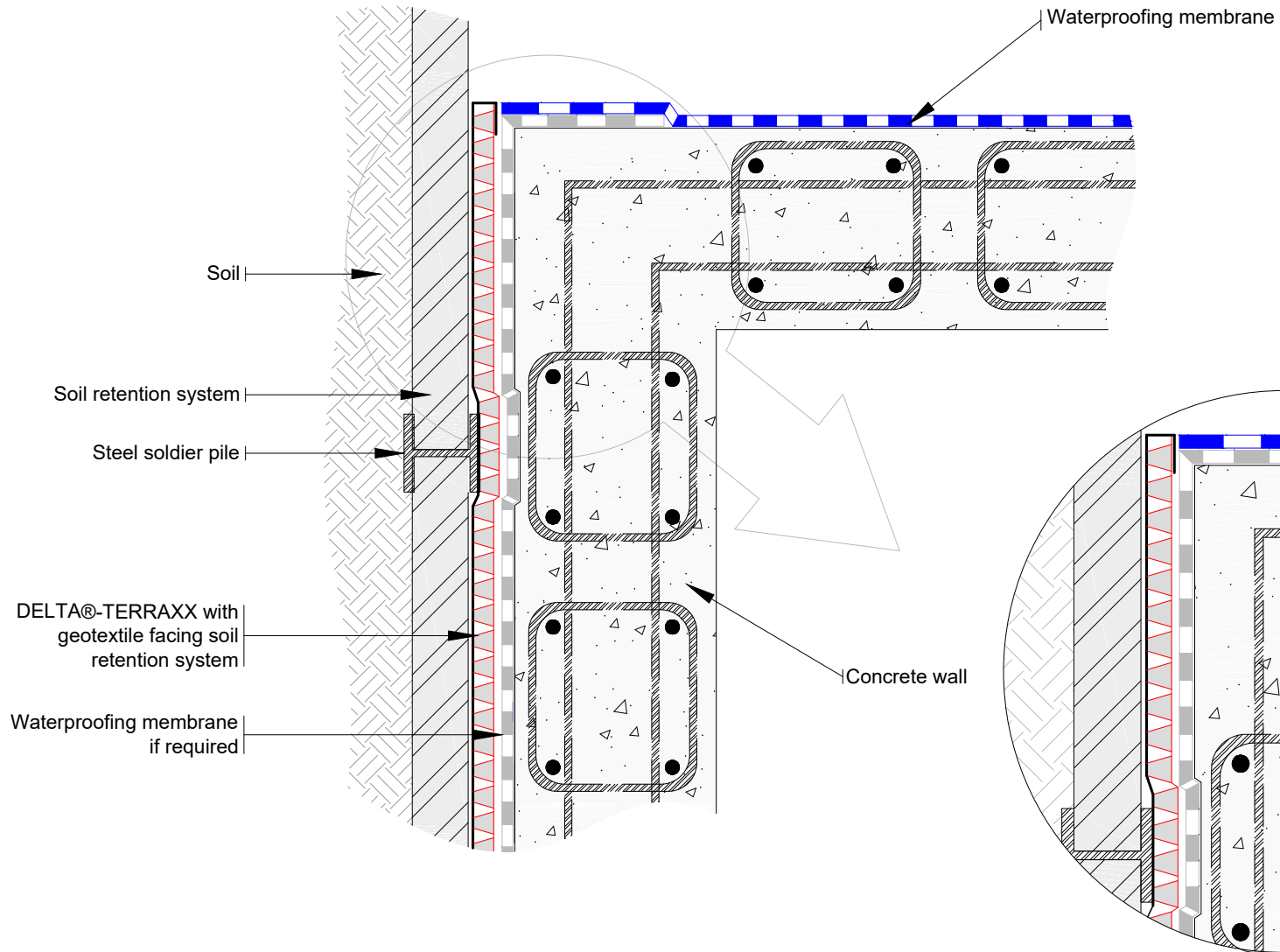

SUBSTANTIAL EFFORT HAS BEEN MADE TO ENSURE THAT THE INFORMATION IN THIS DETAIL DRAWING IS ACCURATE. DÖRKEN SYSTEMS INC. CANNOT ACCEPT RESPONSIBILITY FOR ANY ERRORS OR OVERSIGHTS IN THE USE OF THIS MATERIAL OR IN THE PREPARATION OF ARCHITECTURAL OR ENGINEERING PLANS. THE DESIGN PROFESSIONAL MUST RECOGNIZE THAT NO DESIGN DETAIL CAN SUBSTITUTE FOR EXPERIENCED ENGINEERING AND PROFESSIONAL JUDGEMENT.

TITLE:

DELTA®-TERRAXX TIE-IN TO SELF-ADHERING WATERPROOFING MEMBRANE DETAIL

DRAWN BY: Krzysztof Apriasz C. Tech., CPHC®

DATE: November 16, 2022
SCALE: NTS

FILE NAME:
DTARRAXX_12

 **DÖRKEN**

DELTA®

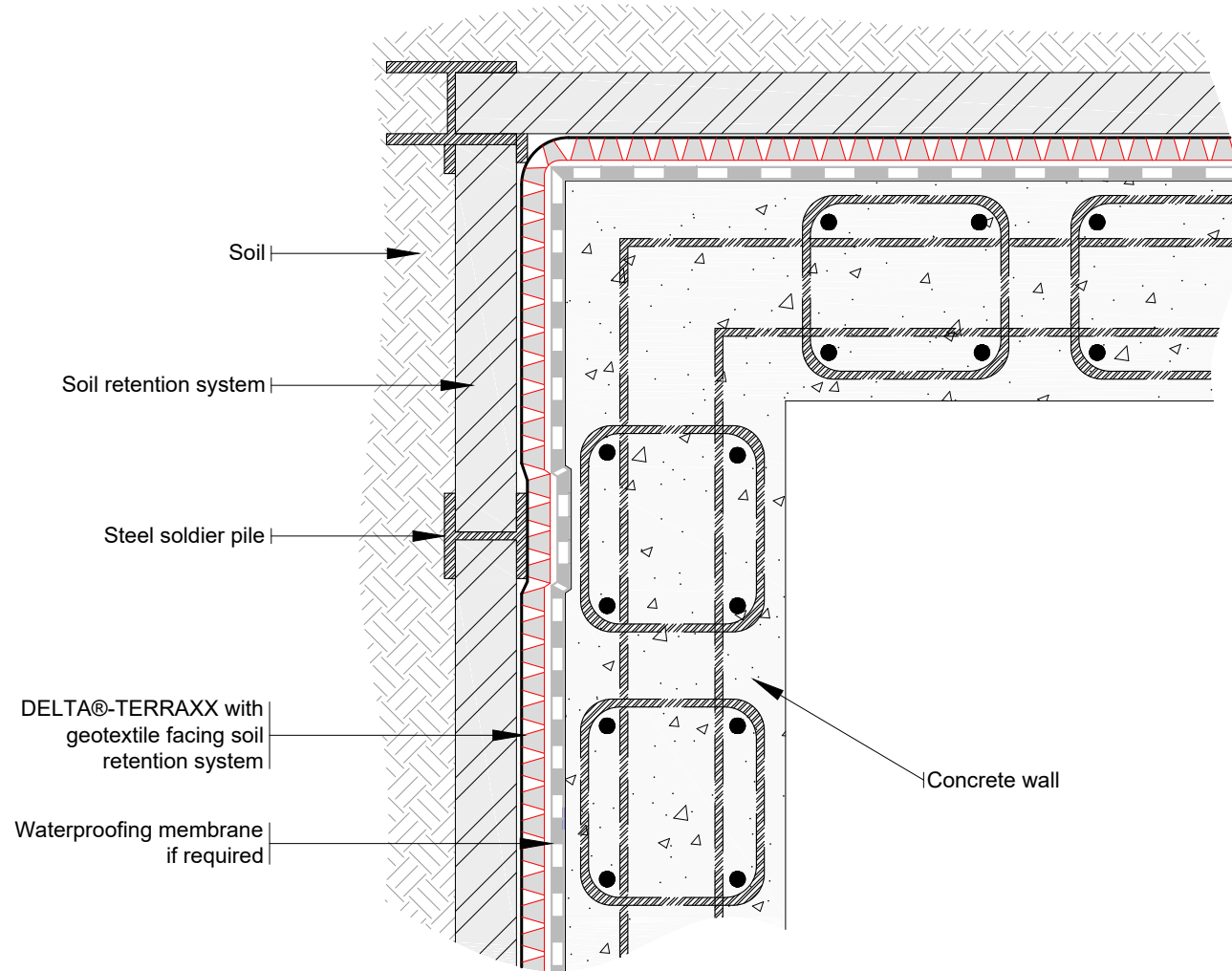

SUBSTANTIAL EFFORT HAS BEEN MADE TO ENSURE THAT THE INFORMATION IN THIS DETAIL DRAWING IS ACCURATE. DÖRKEN SYSTEMS INC. CANNOT ACCEPT RESPONSIBILITY FOR ANY ERRORS OR OVERSIGHTS IN THE USE OF THIS MATERIAL OR IN THE PREPARATION OF ARCHITECTURAL OR ENGINEERING PLANS. THE DESIGN PROFESSIONAL MUST RECOGNIZE THAT NO DESIGN DETAIL CAN SUBSTITUTE FOR EXPERIENCED ENGINEERING AND PROFESSIONAL JUDGEMENT.

TITLE:

TYPICAL CORNER DETAIL DELTA®-TERRAXX

DRAWN BY: Krzysztof Apriasz C. Tech., CPHC®

DATE: November 16, 2022
SCALE: NTS

FILE NAME:
DTERRAXX_13

 **DÖRKEN**

DELTA®

Note: overburden not shown for clarity

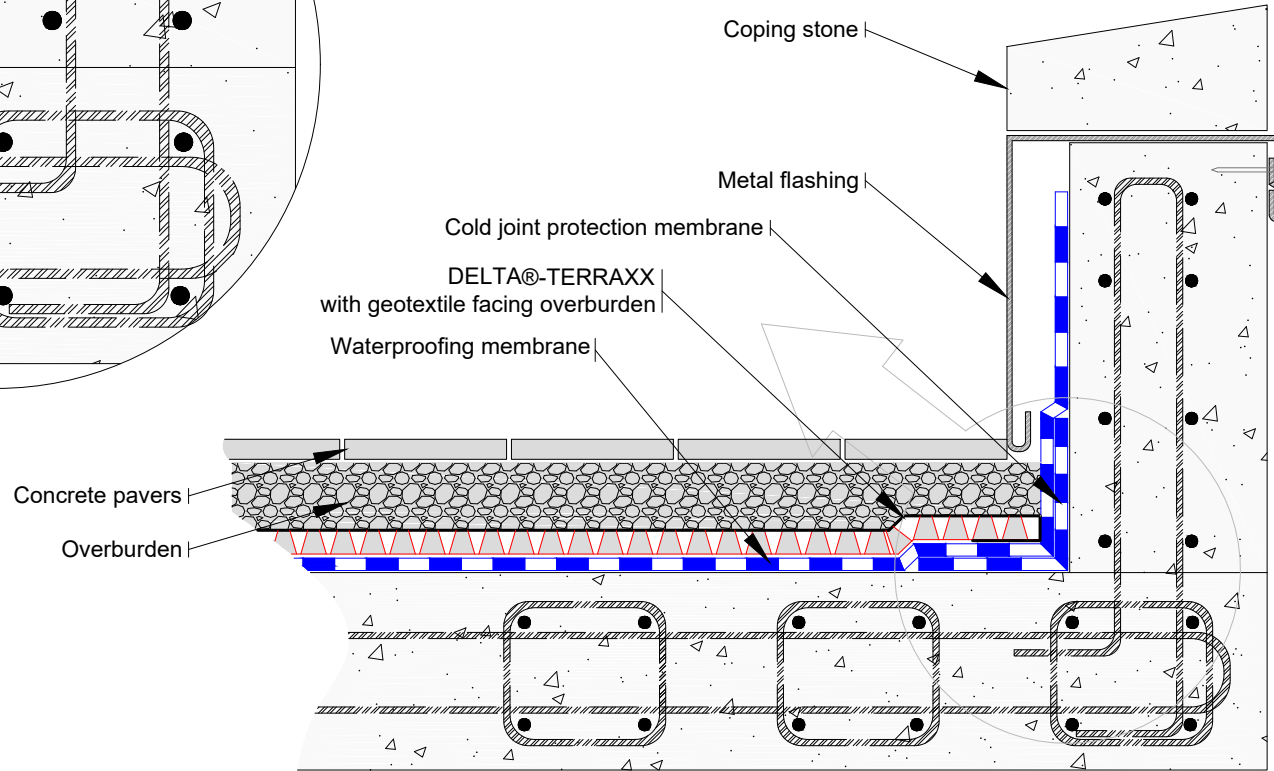
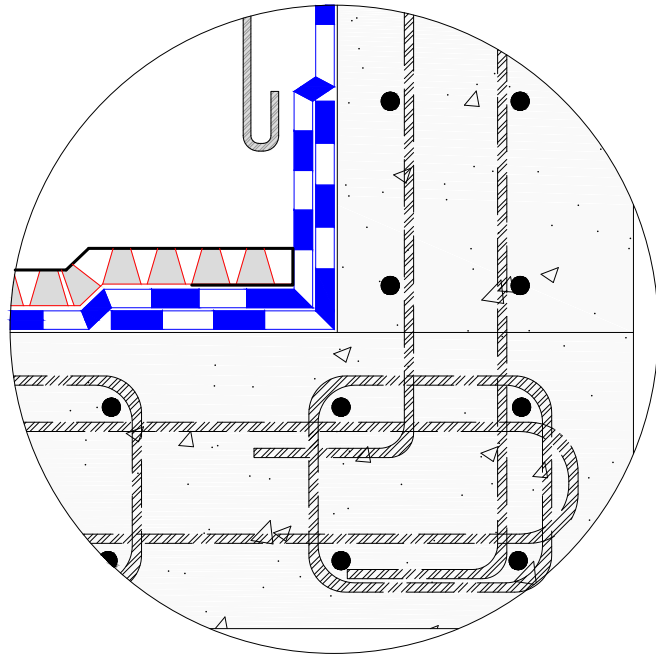

SUBSTANTIAL EFFORT HAS BEEN MADE TO ENSURE THAT THE INFORMATION IN THIS DETAIL DRAWING IS ACCURATE. DÖRKEN SYSTEMS INC. CANNOT ACCEPT RESPONSIBILITY FOR ANY ERRORS OR OVERSIGHTS IN THE USE OF THIS MATERIAL OR IN THE PREPARATION OF ARCHITECTURAL OR ENGINEERING PLANS. THE DESIGN PROFESSIONAL MUST RECOGNIZE THAT NO DESIGN DETAIL CAN SUBSTITUTE FOR EXPERIENCED ENGINEERING AND PROFESSIONAL JUDGEMENT.

TITLE:

TYPICAL PARAPET DETAIL WITH DELTA®-TERRAXX

DRAWN BY: Krzysztof Apriasz C. Tech., CPHC®

DATE: November 16, 2022
SCALE: NTS

FILE NAME:
DTERRAXX_14



DELTA®

Note: overburden not shown for clarity

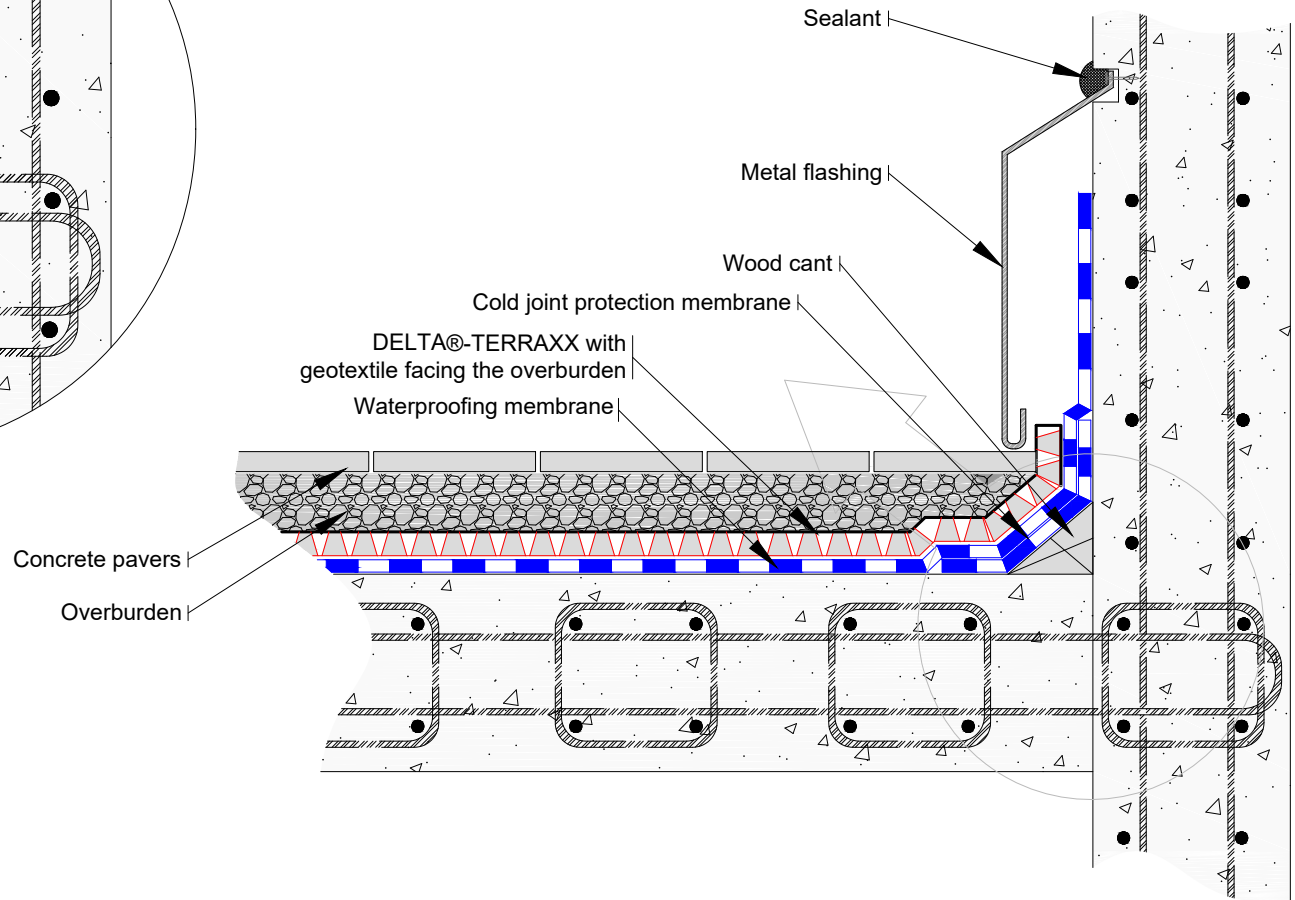
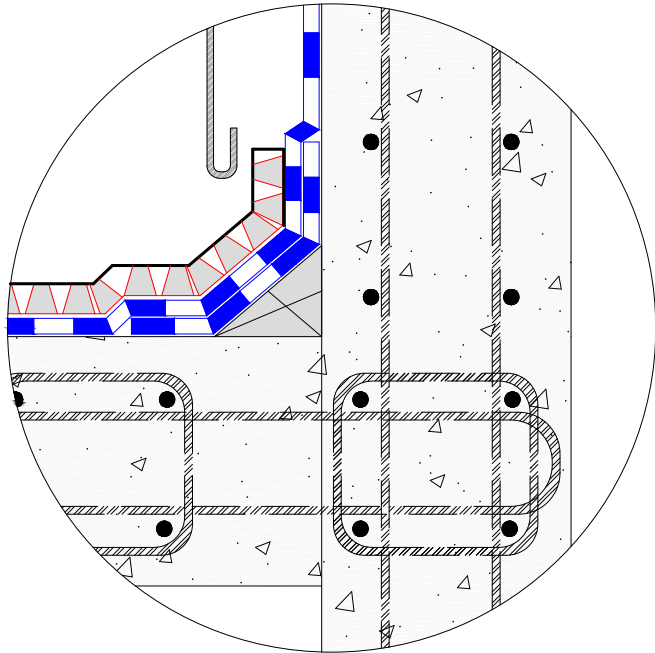

SUBSTANTIAL EFFORT HAS BEEN MADE TO ENSURE THAT THE INFORMATION IN THIS DETAIL DRAWING IS ACCURATE. DÖRKEN SYSTEMS INC. CANNOT ACCEPT RESPONSIBILITY FOR ANY ERRORS OR OVERSIGHTS IN THE USE OF THIS MATERIAL OR IN THE PREPARATION OF ARCHITECTURAL OR ENGINEERING PLANS. THE DESIGN PROFESSIONAL MUST RECOGNIZE THAT NO DESIGN DETAIL CAN SUBSTITUTE FOR EXPERIENCED ENGINEERING AND PROFESSIONAL JUDGEMENT.

TITLE:

TYPICAL ROOF EDGE TERMINATION DETAIL WITH DELTA®-TERRAXX

DRAWN BY: Krzysztof Apriasz C. Tech., CPHC®

DATE: November 16, 2022
SCALE: NTS

FILE NAME:
DTERRAXX_15



DELTA®

Drain Board Comparison Chart

Dörken	DELTA®-DRAIN 2000 HI-X	DELTA®-DRAIN 6000 HI-X	DELTA®-DRAIN 6200 HI-X	DELTA®-DRAIN 9000 HI-X	DELTA®-TERRAXX
American Wick Drain	Sitedrain DS-110 series	6000 and 6200 equivalence; SITEDRAIN Sheet 180 Series	N/A	Sitedrain DS-180 series	N/A
AVM	Drain Board 2000	Drain Board 6000	N/A	Drain Board 9000 Series	N/A
Carlisle	CCW Miradrain 2000	CCW Miradrain 6000	CCW Miradrain 6200	CCW Miradrain 9000	N/A
DMX Drain	DMX Drain 11X	DMX Drain 15X	N/A	DMX Drain 18X	N/A
GCP Applied Technologies	Hydroduct 220	Hydroduct 660	N/A	N/A	N/A
GMX	Drain Max 200 Series	Drain Max 500 Series	N/A	Drain Max 650 Series	N/A
Henry	DB 2000	DB 6000	DB6200	DB 9000	N/A
Hydrotech	N/A	Hydrodrain 400	Hydrodrain 420	Hydrodrain 700	N/A
J-Drain	200	400	420	700	N/A
Mar-Flex	Geo-mat Plus	N/A	N/A	N/A	N/A
Polyguard	N/A	Polyflow 15	Polyflow 15P	Polyflo 18	N/A
PowerHouse	N/A	PowerDrain 6000	N/A	PowerDrain 9000	N/A
Sika	MasterSeal 974	N/A	MasterSeal 975	MasterSeal 976	N/A
Soprema	Sopradrain 10-G	Sopradrain 15-G	N/A	Sopradrain 18-G	N/A
Terrafix	Terradrain 200	Terradrain 600	Terradrain 620	Terradrain 900	N/A
Tremco	TremDrain 2000 NW	TremDrain 6000/6000PF	TremDrain 1000PF	N/A	N/A
WR Meadows	Mel-Drain 5012	Mel-Drain 5035/9055	Mel-Drain 5035-B	Mel-Drain 7955	N/A

DELTA® is a registered trademark of Ewald Dörken AG, Herdecke, Germany.

02/09/2024

DELTA®-TERRAXX

Powerful protection and drainage for deck and below grade wall waterproofing



Leonardo Glass Cube by 3deluxe

- Protection and drainage system
- Extends life of waterproofing membrane
- For applications over waterproofing
- Fast and easy installation
- Available in PLUS version with self-adhesive flat tab





Complete and effective protection and drainage :

DELTA[®]-TERRAXX/PLUS

Innovative Drainage for Roofs, Podium Decks, and Footings

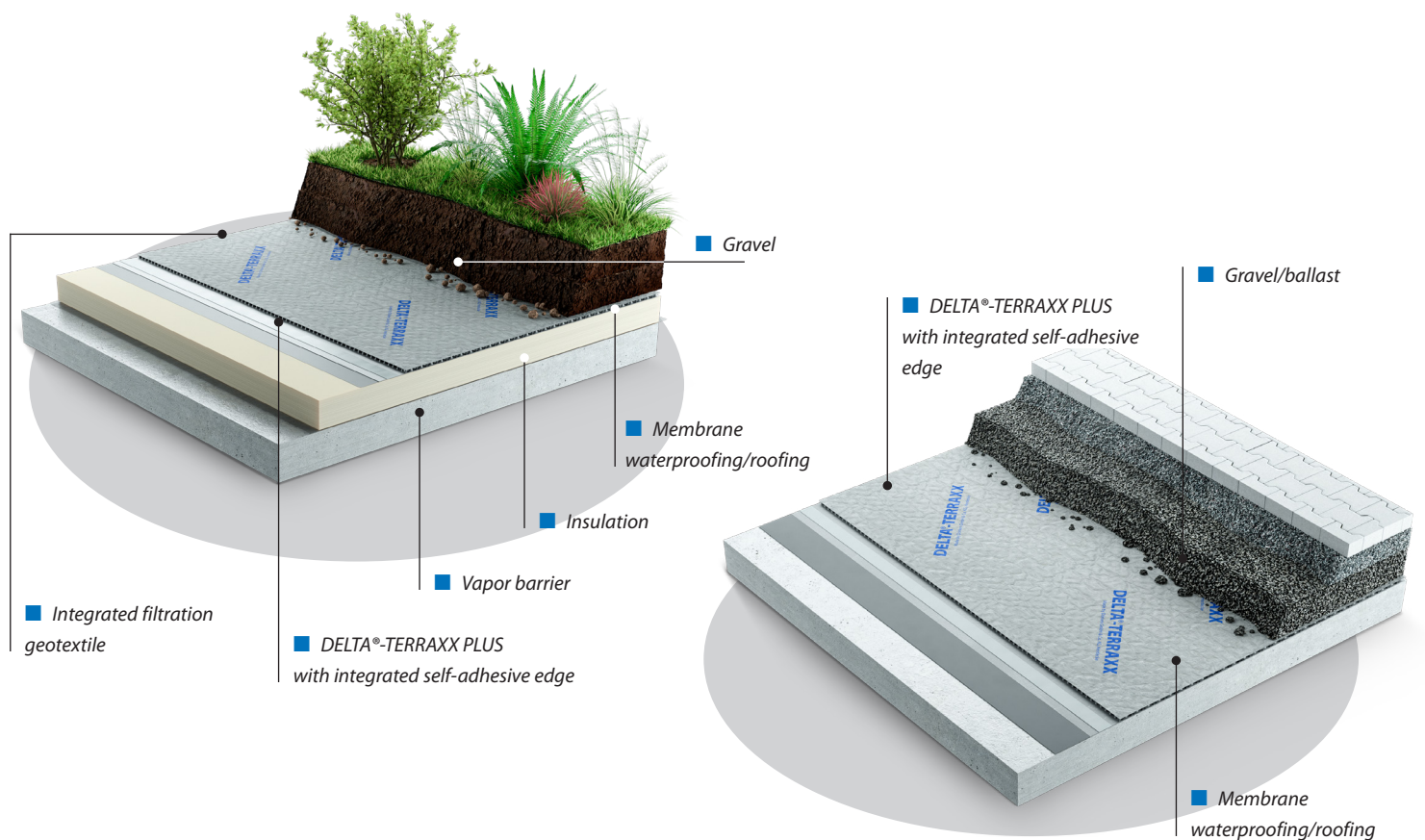

DELTA[®]-TERRAXX PLUS in ballasted or paved roofs.

In roofs that are used by vehicles or pedestrian traffic, DELTA[®]-TERRAXX PLUS functions as protection, filtration, and drainage. Applied on top of waterproofing, it can be covered directly with a layer of sand or aggregate under pavement, interlocking stone, or other traffic toppings. On ballasted roofs, DELTA[®]-TERRAXX PLUS protects the primary roof membrane from mechanical

damage, aggregate penetration, and water accumulation. DELTA[®]-TERRAXX PLUS drainage layer ensures that any precipitation is drained away without delay. If the drainage layer was composed only of the aggregate, its drainage function would be limited, risking the accumulation of water. Freeze/thaw cycles could then cause frost heaving, spalling in the pavement or damage to the

roof. Proper drainage is critical because pooled water could invalidate the roof membrane warranty.



Foundation Walls.

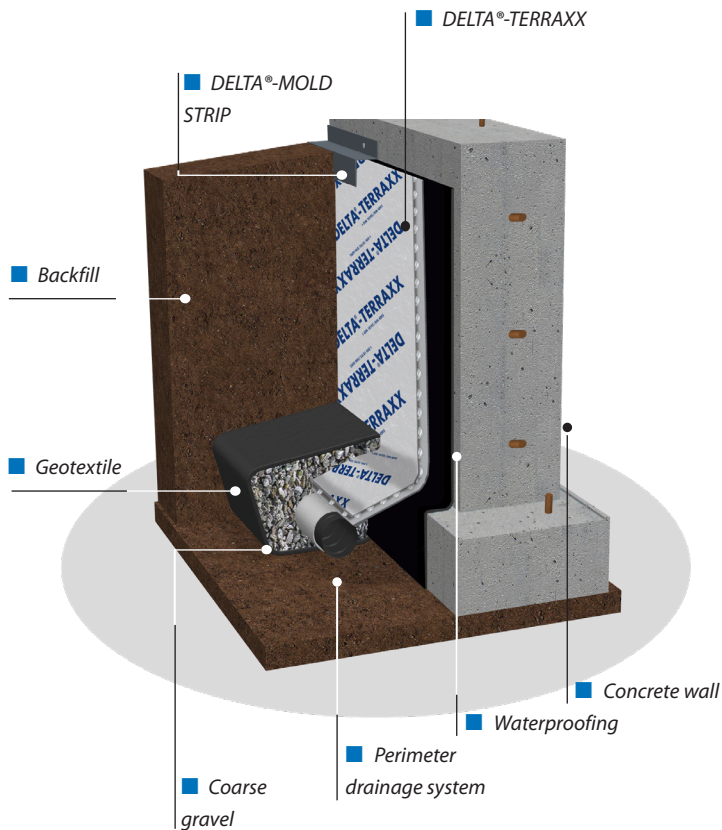

Technical Data :	
Color	Silver
Material	drainage core: virgin HDPE; geotextile (gray)
Dimple height	2/5" (9 mm) ASTM D5199
Compressive strength	approx. 8,500 psf (406 kN/m ²) ASTM D6364-06
Geotextile grab tensile strength	120 lbs (534 N) ASTM D4632
Geotextile elongation	60% ASTM D4632
Geotextile trapezoidal tear	35 lbs (156 N) ASTM D4533
Geotextile puncture strength	25 lbs (110 N) ASTM D4833
Geotextile apparent opening size (AOS)	50 sieve size (0.30 mm) ASTM D4751-99
Geotextile water flow rate	595 gal/min/ft ² (3895 l/min/m ²) ASTM D4491
Permittivity	0.8 sec-1 ASTM D4491
Geotextile weight (typical)	3.0 oz/yd ² (104 g/m ²) ASTM D5261-92
Geocomposite water flow rate @ hydr. grad. 1.0	16.6 gal/min/ft (206 l/min/m) ASTM D4716-99
Geocomposite water flow rate @ hydr. grad. 0.1	4.77 gal/min/ft (59 l/min/m) ASTM D4716-99
Toxicity	non-toxic, non-polluting
Roll dimensions/ weight	6'-7" x 41' (2 m x 12.5 m) 51 lbs (23 kg)
Service life expectancy	±25 years (at pH between 4 and 9 and temperature below 77°F / 25°C). Do not expose to UV light for more than 30 days.

DELTA®-TERRAXX for below grade walls.

Management of water on foundation walls is critical to the long term sustainability and durability of any below grade structure. DELTA®-TERRAXX provides multiple functions: protection, filtration, and drainage. Forming a robust protection and drainage layer, it effectively prevents water from accumulating by providing space for water to flow safely to collection points. Its water

drainage capacity is remarkably greater than that of gravel or other aggregates alone. Its smooth back ensures that loads are distributed evenly across the entire surface of the waterproofing. DELTA®-TERRAXX is compatible with all commercial waterproofing. No additional protective layer is needed. As a water management layer, DELTA®-TERRAXX protects against backfill

damage and seepage water. The optimal solution for maximum security.

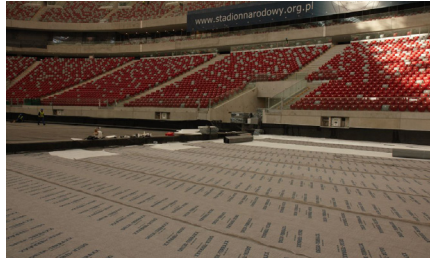

Dependable and lasting drainage performance.

True Performance Under Load

Conventional drainboards use needlepunched filter fabrics that stretch under load.

DELTA®-TERRAXX provides more reliable drainage performance in jobsite conditions.

Its high-performance polypropylene geotextile is exceptionally strong. The high initial modulus combined with minimum deformation under increasing load ensures that flow rates are not compromised.

The geotextile is made from thermally bonded, continuous polypropylene fibers. The thin 3-dimensional structure of the geotextile is engineered to reduce the risk of clogging.

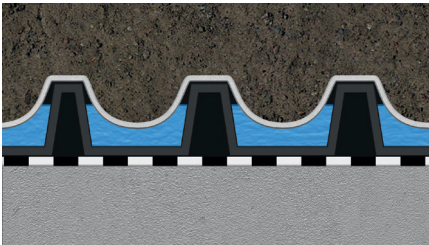

Drainboard with conventional filter fabric

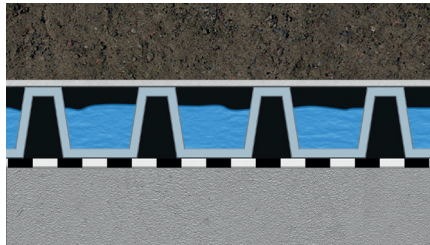

DELTA®-TERRAXX



Longterm Durability

DELTA®-TERRAXX is made from a specially formulated, highly durable HDPE to ensure reliable long-term drainage and waterproofing protection.

We use a potent blend of additives and anti-oxidants to stabilize the polymer against aging and degradation. As a result, DELTA®-TERRAXX is exceptionally resilient against stress-cracking and oxidation. This ensures reliable drainage performance of DELTA®-TERRAXX throughout its service life.

DELTA®-TERRAXX PLUS Integrated Self-adhering Edge

Also available as DELTA®-TERRAXX PLUS, with an exclusive integrated self-adhesive flat tab for greater placement stability. The lay-flat design requires no ballast during installation, even in wind. This means an open, stable and unobstructed work surface.

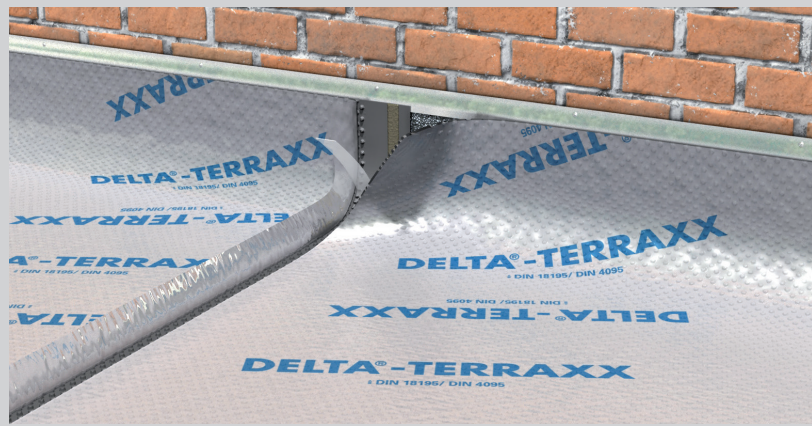

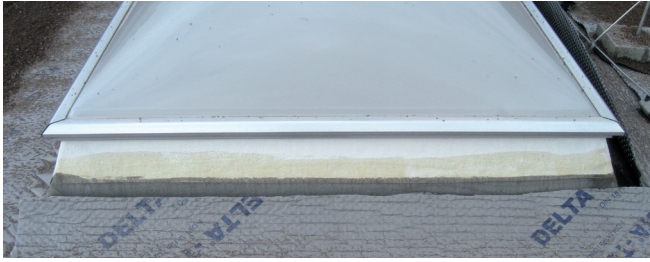

Large rolls for few overlaps and fast coverage.

Minimizes labor

DELTA®-TERRAXX's roll size is 6' 7" (2 m) wide and 41' (12.5 m) long. The larger roll size is light and easy to carry bringing extra efficiency to every job-site.

The larger rolls reduce handling costs dramatically due to fewer rolls being required. Installation is significantly faster.

There is less rolling out, less overlapping and less detailing required.

With the integrated self-adhering edge of the PLUS version, the membrane stays in place. No wasted effort repositioning previously placed membrane.

DELTA®-TERRAXX brings extra efficiency to every job-site.

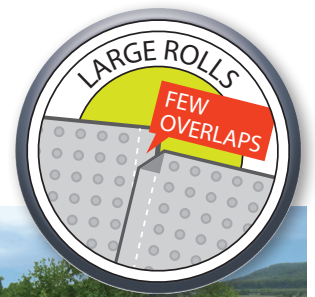

DELTA®-Accessories for DELTA®-TERRAXX.

Dörken makes your life easier – systematically.

You are sure to appreciate these handy DELTA®-Accessories:



DELTA®-FAST'ner
multistud fastener for the secure attachment of DELTA®-TERRAXX.



DELTA®-MOLDSTRIP
used at terminations of DELTA®-TERRAXX.



DELTA®-MULTI BAND
pure acrylic adhesive tape used at overlaps.

DELTA®



Dörken Systems Inc.
4655 Delta Way
Beamsville,
ON L3J 0T6 Canada
Tel.: +1 (905) 563 3255
Fax: +1 (905) 563 5582
info@dorken.com
www.dorken.com

A DÖRKENGROUP company

■ The information printed in this brochure reflects product information and specifications at the date of printing. The manufacturer reserves the right to make changes when necessary.
All rights reserved.

DELTA® – branded quality products manufactured by Dörken.

■ Visit us on:

